

# ICC-ES Evaluation Report

**ESR-2251**

Reissued September 2019

This report is subject to renewal September 2021.

[www.icc-es.org](http://www.icc-es.org) | (800) 423-6587 | (562) 699-0543

A Subsidiary of the International Code Council®

**DIVISION: 03 00 00—CONCRETE**  
**Section: 03 16 00—Concrete Anchors**

**DIVISION: 05 00 00—METALS**  
**Section: 05 05 19—Post-installed Concrete Anchors**

**REPORT HOLDER:**

ITW RED HEAD

**ADDITIONAL LISTEE:**

ITW BRANDS

**EVALUATION SUBJECT:**

ITW RED HEAD TRUBOLT CARBON STEEL WEDGE ANCHORS IN CONCRETE

**1.0 EVALUATION SCOPE**

**Compliance with the following codes:**

- 2018, 2015, 2012, 2009, and 2006 *International Building Code*® (IBC)
- 2018, 2015, 2012, 2009, and 2006 *International Residential Code*® (IRC)

**Property evaluated:**

Structural

**2.0 USES**

The RED HEAD Trubolt Wedge Anchors are used to resist static, wind, and earthquake (Seismic Design Categories A and B only) tension and shear loads in uncracked normal-weight concrete and lightweight concrete having a specified compressive strength,  $f'_c$ , ranging from 2,500 psi to 8,500 psi (17.2 MPa to 58.6 MPa). The anchoring system complies with anchors as described in Section 1901.3 of the 2018 and 2015 IBC, Section 1909 of the 2012 IBC, and Section 1912 of the 2009 and 2006 IBC. The anchors are an alternative to cast-in-place anchors described in Section 1908 of the 2012 IBC, and Section 1911 of the 2009 and 2006 IBC. The anchors may also be used where an engineered design is submitted in accordance with Section R301.1.3 of the IRC.

**3.0 DESCRIPTION**

**3.1 RED HEAD Carbon Steel Trubolt Wedge Anchor:**

The RED HEAD Trubolt wedge anchor is a zinc plated, torque-controlled expansion anchor, available in 1/4-inch, 3/8-inch and 1/2-inch diameters (6.4, 9.5 and 12.7 mm). The

Trubolt wedge anchor consists of a fully threaded stud, expansion clip, nut and washer. The anchor stud is cold-formed from carbon steel materials. The zinc plating on the anchor body complies with ASTM B633 SC1, Type III, with a minimum 0.0002-inch (5  $\mu$ m) thickness. The expansion clip is fabricated from Type 302 or Type 430 stainless steels. The standard hexagonal nut conforms to ANSI B18.2.2-65, and the washer conforms to ANSI/ASME B18.22.1 1965 (R1981). The anchor stud is threaded throughout the majority of its length and has a wedge section at the far end, around which the expansion clip is formed. The expansion clip, consisting of a split-ring element with a “coined” groove at each end, is shown in Figure 1. During installation of the anchor, the expansion clip engages the walls of the concrete as the wedge portion of the stud is forced upward against the interior of the clip.

**3.2 Concrete:**

Normal-weight and lightweight concrete must comply with Sections 1903 and 1905 of the IBC.

**4.0 DESIGN AND INSTALLATION**

**4.1 Strength Design:**

**4.1.1 General:** Design strength of anchors in accordance with the 2018 and 2015 IBC, as well as Section R301.1.3 of the 2018 and 2015 IRC, must be determined in accordance with ACI 318-14 Chapter 17 and this report.

Design strength of anchors in accordance with the 2012 IBC, as well as Section R301.1.3 of the 2012 IRC, must be determined in accordance with ACI 318-11 Appendix D and this report.

Design strength of anchors in accordance with the 2009 IBC and Section R301.1.3 of the 2009 IRC must be in accordance with ACI 318-08 Appendix D and this report.

Design strength of anchors in accordance with the 2006 IBC and Section R301.1.3 of the 2006 IRC must be in accordance with ACI 318-05 Appendix D and this report.

Design parameters and references to ACI 318 are based on the 2018 and 2015 IBC (ACI 318-14) and on the 2012 IBC (ACI 318-11) unless noted otherwise in Sections 4.1.1 through 4.1.11 of this report. The strength design of anchors must comply with ACI 318-14 17.3.1 or ACI 318-11 D.4.1, as applicable, except as required in ACI 318-14 17.2.3 or ACI 318-11 D.3.3, as applicable. A design example in accordance with the 2012 IBC is provided in Figure 4 of this report.

Strength reduction factors,  $\phi$ , as given in ACI 318-14 17.3.3 or ACI 318-11 D.4.3 (ACI 318-08 and -05 D.4.4)

must be used for load combinations calculated in accordance with Section 1605.2 of the IBC, Section 5.3 of ACI 318-14, and Section 9.2 of ACI 318-11, as applicable. Strength reduction factors,  $\phi$ , as given in ACI 318-11 D.4.4 (ACI 318-08 and -05 D.4.5) must be used for load combinations calculated in accordance with ACI 318-11, -08, and -05 Appendix C. The value of  $f'_c$  used in calculations must be limited to 8,000 psi (55.2 MPa), maximum, in accordance with ACI 318-14 17.2.7 or ACI 318-11 D.3.7, as applicable. Strength reduction factors,  $\phi$ , corresponding to ductile steel elements may be used.

**4.1.2 Requirements for Static Steel Strength in Tension,  $N_{sa}$ :** The nominal static steel strength of a single anchor in tension,  $N_{sa}$ , calculated in accordance with ACI 318-14 17.4.1.2 or ACI 318-11 D.5.1.2, as applicable, is given in Table 3 of this report.

**4.1.3 Requirements for Static Concrete Breakout Strength in Tension,  $N_{cb}$ ,  $N_{cbg}$ :** The nominal concrete breakout strength of a single anchor or group of anchors in tension,  $N_{cb}$  or  $N_{cbg}$ , respectively, must be calculated in accordance with ACI 318-14 17.4.2 or ACI 318-11 D.5.2, as applicable, with modifications as described in this section. The values of  $f'_c$  used for calculation purposes must not exceed 8,000 psi (55.2 MPa). The basic concrete breakout strength of a single anchor in tension,  $N_b$ , must be calculated in accordance with ACI 318-14 17.4.2.2 or ACI 318-11 D.5.2.2, using the values of  $h_{ef}$  and  $k_{uncr}$  as given in Table 3 of this report. The nominal concrete breakout strength in tension in regions where analysis indicates no cracking in accordance with ACI 318-14 17.4.2.6 or ACI 318-11 D.5.2.6 must be calculated with  $\psi_{c,N} = 1.0$ .

**4.1.4 Requirements for Static Pullout Strength in Tension,  $N_{pn}$ :** The pullout nominal strength in tension for a single anchor in accordance with ACI 318-14 17.4.3.1 and 17.4.3.2 or ACI 318-11 D.5.3.1 and D.5.3.2, respectively, as applicable, in uncracked concrete,  $N_{p,uncr}$ , is given in Table 4 of this report. For all design cases  $\psi_{c,P} = 1.0$ .

**4.1.5 Requirements for Static Steel Strength in Shear,  $V_{sa}$ :** The values of  $V_{sa}$  for a single anchor given in Table 3 of this report must be used in lieu of the values of  $V_{sa}$  as derived by calculation according to ACI 318-14 17.5.1.2 or ACI 318-11 D.6.1.2, as applicable. The strength reduction factor,  $\phi$ , corresponding to a ductile steel element must be used for the Trubolt anchors as described in Table 3 of this report.

**4.1.6 Requirements for Static Concrete Breakout Strength in Shear,  $V_{cb}$  or  $V_{cbg}$ :** The nominal static concrete breakout strength in shear of a single anchor or a group of anchors,  $V_{cb}$  or  $V_{cbg}$ , respectively, must be calculated in accordance with ACI 318-14 17.5.2 or ACI 318-11 D.6.2, as applicable, with modifications as described in this section. The basic concrete breakout strength in shear of a single anchor in cracked concrete,  $V_b$ , must be calculated in accordance with ACI 318-14 17.5.2.2 or ACI 318-11 D.6.2.2, as applicable, using the value of  $d_a$ , given in Table 2 of this report, and the value  $h_{ef}$ , given in Table 3.  $l_e$  must be taken as no greater than  $h_{ef}$  and in no case must  $l_e$  exceed  $8d_a$ .

**4.1.7 Requirements for Static Concrete Pryout Strength of Anchor in Shear,  $V_{cp}$  or  $V_{cpg}$ :** The nominal static concrete pryout strength in shear of a single anchor or groups of anchors,  $V_{cp}$  or  $V_{cpg}$ , must be calculated in accordance with ACI 318-14 17.5.3 or ACI 318-11 D.6.3, as applicable, modified by using the value of  $k_{cp}$  provided in Table 3 of this report and the value of  $N_{cb}$  or  $N_{cbg}$  as calculated in Section 4.1.3 of this report

**4.1.8 Requirements for Minimum Member Thickness, Minimum Anchor Spacing and Minimum Edge Distance:** Values of  $s_{min}$  and  $c_{min}$  as given in Table 2 of this report must be used in lieu of ACI 318-14 17.7.1 and 17.7.3 or ACI 318-11 D.8.1 and D.8.3, respectively, as applicable. Minimum member thicknesses,  $h_{min}$ , as given in Table 2 of this report, must be used in lieu of ACI 318-14 17.7.5 or ACI 318-11 D.8.5, as applicable

**4.1.9 Requirements for Critical Edge Distance:** In applications where  $c < c_{cr}$  and supplemental reinforcement to control splitting of the concrete is not present, the concrete breakout strength in tension for uncracked concrete, calculated according to ACI 318-14 17.4.2 or ACI 318-11 D.5.2, as applicable, must be further multiplied by the factor  $\psi_{cp,N}$ , as given by the following equation:

$$\Psi_{cp,N} = C / C_{ac} \quad (\text{Eq-1})$$

where  $c \geq c_{min}$  from Table 2, and whereby the factor  $\psi_{cp,N}$  need not be taken as less than  $1.5h_{ef} / c_{ac}$ . For all other cases,  $\psi_{cp,N} = 1.0$ . In lieu of ACI 318-14 17.7.6 or ACI 318-11 D.8.6, as applicable, values for  $c_{ac}$  must be taken from Table 3 of this report.

**4.1.10 Interaction of Tensile and Shear forces:** For designs that include combined tension and shear, the interaction of tension and shear loads must be calculated in accordance with ACI 318-14 17.6 or ACI 318-11 D.7, as applicable.

**4.1.11 Lightweight Concrete:** For the use of anchors in lightweight concrete, the modification factor  $\lambda_a$  equal to  $0.8\lambda$  is applied to all values of  $\sqrt{f'_c}$  affecting  $N_n$  and  $V_n$ .

For ACI 318-14 (2018 and 2015 IBC), ACI 318-11 (2012 IBC) and ACI 318-08 (2009 IBC),  $\lambda$  shall be determined in accordance with the corresponding version of ACI 318.

For ACI 318-05 (2006 IBC),  $\lambda$  shall be taken as 0.75 for all lightweight concrete and 0.85 for sand-lightweight concrete. Linear interpolation shall be permitted if partial sand replacement is used. In addition, the pullout strengths  $N_{p,uncr}$  shall be multiplied by the modification factor,  $\lambda_a$ , as applicable.

## 4.2 Allowable Stress Design (ASD):

**4.2.1 General:** For anchors designed using the allowable stress design load combinations in accordance with IBC Section 1605.3, allowable loads must be established using Eq-2 and Eq-3:

$$T_{allowable,ASD} = \phi N_n / \alpha \quad (\text{Eq-2})$$

and

$$V_{allowable,ASD} = \phi V_n / \alpha \quad (\text{Eq-3})$$

where

$$T_{allowable,ASD} = \text{Allowable tension load (lbf or kN).}$$

$$V_{allowable,ASD} = \text{Allowable shear load (lbf or kN).}$$

$\phi N_n$  = Lowest design strength of an anchor or anchor group in tension as determined in accordance with ACI 318-14 Chapter 17, 2018 and 2015 IBC Section 1905.1.8, ACI 318-11 Appendix D, ACI 318-08 Appendix D and 2009 IBC Section 1908.1.9, and ACI 318-05 Appendix D and 2006 IBC Section 1908.1.16, with amendments in Section 4.1 of this report, as applicable (lb or kN).

$\phi V_n$  = Lowest design strength of an anchor or anchor group in shear as determined in accordance with ACI 318-14 Chapter 17, 2018 and 2015 IBC Section 1905.1.8, ACI 318-11 Appendix D, ACI 318-08 Appendix D and 2009 IBC Section 1908.1.9, ACI 318-05 Appendix D and 2006 IBC Section 1908.1.16, and Section 4.1 of this report as applicable. (lb or kN).

$\alpha$  = Conversion factor calculated as a weighted average of the load factors for the controlling load combination. In addition,  $\alpha$  must include all applicable factors to account for nonductile failure modes and required over-strength.

The requirements for member thickness, edge distance and spacing, as described in this report, must apply. An example of allowable stress design values for illustrative purposes is shown in Table 5 of this report.

**4.2.2 Interaction of Tensile and Shear Forces:** In lieu of ACI 318-14 17.6 or ACI 318-11 D.7, interaction must be calculated as follows:

For shear loads  $V \leq 0.2 V_{allowable, ASD}$ , the full allowable load in tension  $T_{allowable, ASD}$  may be taken.

For tension loads  $T \leq 0.2 T_{allowable, ASD}$ , the full allowable load in shear  $V_{allowable, ASD}$  may be taken.

For all other cases, Eq-4 applies:

$$T/T_{allowable, ASD} + V/V_{allowable, ASD} \leq 1.2 \quad (\text{Eq-4})$$

#### 4.3 Installation:

The anchors must be installed in accordance with the manufacturer's printed installation instructions (MPII) as depicted in Figure 3, and this report. Anchor locations must comply with this report and the plans and specifications approved by the code official. Embedment, spacing, edge distance, and concrete thickness are shown in Figure 2, and Tables 2 and 3. Holes must be predrilled in concrete with a compressive strength from 2,500 to 8,500 psi (17.2 to 58.6 MPa), using carbide-tipped masonry drill bits complying with ANSI B212.15-1994. The nominal drill bit diameter must be equal to the anchor diameter. The drilled hole depth,  $h_o$ , must exceed the required embedment in concrete as noted in Table 2. The hole must be cleaned with pressurized air or vacuum prior to installation of the anchor. The anchors must be hammered into the predrilled hole to the required embedment depth in concrete. A standard hexagonal nut and washer must be used over the material being fastened and the nut tightened (three to five turns) until the minimum installation torque, as specified in Table 2, is reached.

#### 4.4 Special Inspection:

Periodic special inspection is required, in accordance with Section 1705.1.1 and Table 1705.3 of the 2018, 2015 and 2012 IBC; Section 1704.15 and Table 1704.4 of the 2009 IBC; or Section 1704.13 of the 2006 IBC, as applicable. The special inspector must make periodic inspections during anchor installation to verify anchor type, anchor dimensions, concrete type, concrete compressive strength, hole dimensions, hole cleaning procedures, anchor spacing, edge distance, concrete member thickness, anchor embedment, tightening torque. And adherence to the manufacturer's printed installation instructions. The special inspector must be present as often as required in accordance with the "statement of special inspection". Under the IBC, additional requirements as set forth in

Sections 1705, 1706, and 1707 must be observed, where applicable.

## 5.0 CONDITIONS OF USE

The Trubolt Wedge Anchors described in this report comply with, or are suitable alternatives to what is specified in, the codes listed in Section 1.0 of this report, subject to the following conditions:

- 5.1 Anchor sizes, dimensions, and installation are as set forth in this report.
- 5.2 The anchors must be installed in accordance with the manufacturer's printed installation instructions and this report in uncracked normal-weight or lightweight concrete having a specified compressive strength,  $f'_c$ , of 2,500 psi to 8,500 psi (17.2 MPa to 58.6 MPa). In case of conflict, this report governs.
- 5.3 The values of  $f'_c$  used for calculation purposes must not exceed 8,000 psi (55.1 MPa).
- 5.4 Loads applied to the anchors must be adjusted in accordance with Section 1605.2 of the IBC for strength design, and in accordance with Section 1605.3 of the IBC for allowable stress design.
- 5.5 Strength design values must be established in accordance with Section 4.1 of this report.
- 5.6 Allowable design values are established in accordance with Section 4.2 of this report.
- 5.7 Anchor spacing and edge distance, as well as minimum member thickness, must comply with Table 2 and Table 3 of this report.
- 5.8 Prior to installation, calculations and details justifying that the applied loads comply with this report must be submitted to the building official for approval. The calculations and details must be prepared by a registered design professional where required by the statutes of the jurisdiction in which the project is to be constructed.
- 5.9 Since an ICC-ES acceptance criteria for evaluating data to determine the performance of expansion anchors subjected to fatigue or shock loading is unavailable at this time, the use of these anchors under such conditions is beyond the scope of this report.
- 5.10 The use of Trubolt anchors is limited to installation in uncracked normal-weight and lightweight concrete. Anchors may not be installed in regions of a concrete member where cracking has occurred or where analysis indicates cracking may occur at service load levels, subject to the conditions of this report.
- 5.11 Anchors used to resist seismic loads are limited to locations designated as Seismic Design Categories A and B.
- 5.12 Anchors may be used to resist short-term loading due to wind forces, subject to the conditions of this report.
- 5.13 Where not otherwise prohibited in the code, Trubolt wedge anchors are permitted for use with fire-resistance-rated construction provided that at least one of the following conditions is fulfilled:
  - Anchors are used to resist wind or seismic forces only.
  - Anchors that support a fire-resistance-rated envelope or a fire-resistance-rated membrane are protected by approved fire-resistance-rated materials, or have been evaluated for resistance to

fire exposure in accordance with recognized standards.

- Anchors are used to support nonstructural elements.

**5.14** Use of zinc-coated carbon steel anchors is limited to dry, interior locations.

**5.15** Special inspections are provided in accordance with Section 4.4 of this report.

**5.16** Anchors are manufactured under an approved quality control program with inspections by ICC-ES.

**6.0 EVIDENCE SUBMITTED**

Data in accordance with the ICC-ES Acceptance Criteria for Mechanical Anchors in Concrete Elements (AC193), dated October 2017 (Editorially revised in April 2018) for use in uncracked concrete; and quality control documentation.

**7.0 IDENTIFICATION**

**7.1** The concrete anchors are identified by their dimensional characteristics, the anchor size, and by

the length code stamped on the anchor, as indicated in Table 1. Packages are identified with the anchor type and size, the manufacturer’s name and address, and the evaluation report number (ESR-2251).

**7.2** The report holder’s contact information is the following:

**ITW RED HEAD**  
**700 HIGH GROVE BOULEVARD**  
**GLENDALE HEIGHTS, ILLINOIS 60139**  
**(800) 848-5611**  
[www.itw-redhead.com](http://www.itw-redhead.com)  
[techsupport@itwccna.com](mailto:techsupport@itwccna.com)

**7.3** The additional listee’s contact information is the following:

**ITW BRANDS**  
**955 NATIONAL PARKWAY, SUITE 95500**  
**SCHAUMBURG, ILLINOIS 60173**  
**(877) 489-2726**  
[www.itwbrands.com](http://www.itwbrands.com)

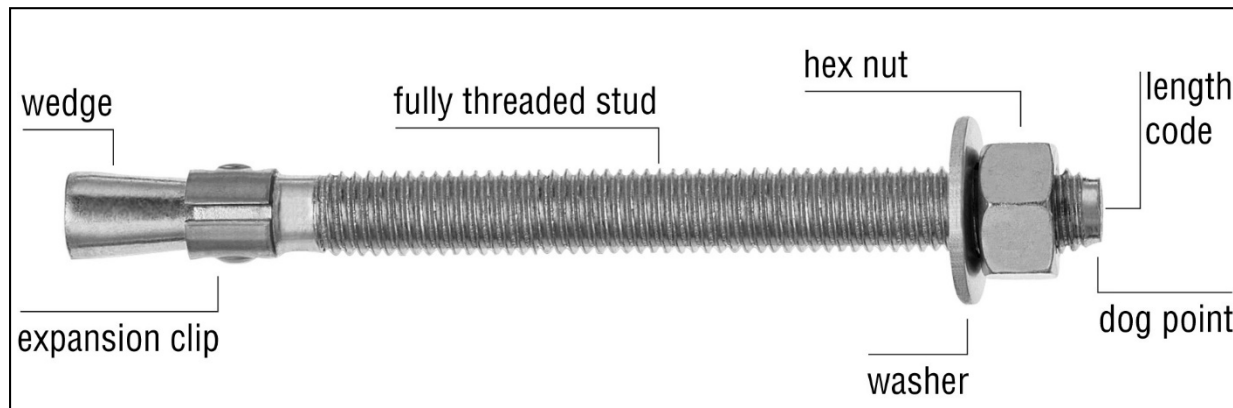

**FIGURE 1—ITW RED HEAD TRUBOLT WEDGE ANCHOR**

**TABLE 1—LENGTH IDENTIFICATION SYSTEM**

LENGTH ID MARKING ON ANCHOR HEAD		UNITS	A	B	C	D	E	F	G	H	I	J
Length of anchor, lanch	From	in. (mm)	1½ (38.1)	2 (50.8)	2½ (63.5)	3 (76.2)	3½ (88.9)	4 (101.6)	4½ (114.3)	5 (127.0)	5½ (139.7)	6 (152.4)
	Up to, but not including	in. (mm)	2 (50.8)	2½ (63.5)	3 (76.2)	3½ (88.9)	4 (101.6)	4½ (114.3)	5 (127.0)	5½ (139.7)	6 (152.4)	6½ (165.1)



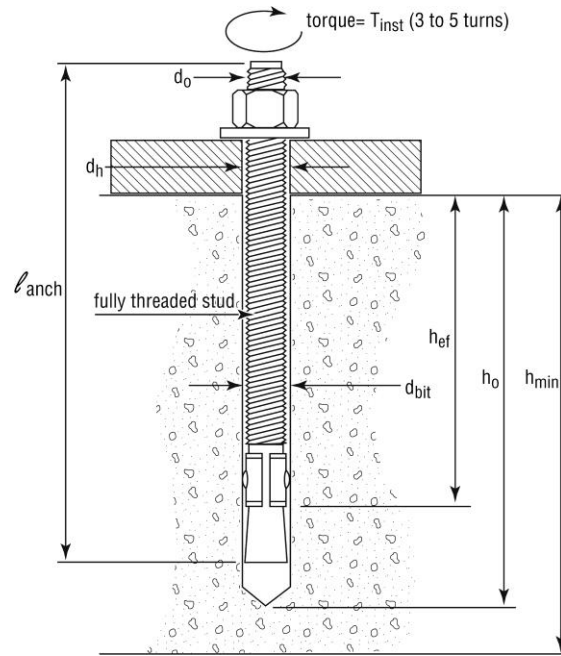
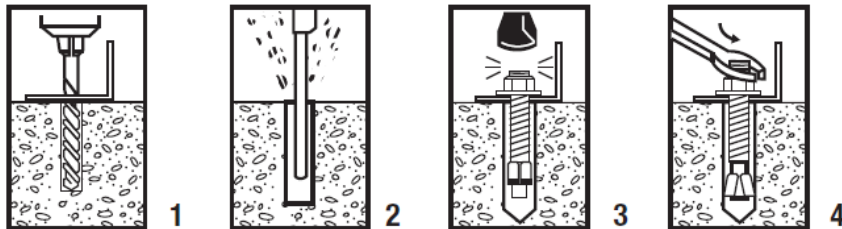

FIGURE 2—ITW RED HEAD TRUBOLT WEDGE ANCHOR (INSTALLED)

### MANUFACTURER'S INSTALLATION STEPS



1. Select a carbide drill bit with a diameter equal to the anchor diameter. Drill hole at least 1/4" deeper than nominal anchor embedment.
2. Clean hole with pressurized air or vacuum to remove any excess dust/debris.
3. Using the washer and nut provided, assemble the anchor, leaving nut one half turn from the end of anchor to protect threads. Drive anchor through fixture to be fastened until washer is flush to surface of fixture.
4. Expand anchor by tightening nut to the specified setting torque - see Table (approx 3 to 5 full revolutions).

FIGURE 3—INSTALLATION INSTRUCTIONS

TABLE 2—ITW TRUBOLT WEDGE ANCHOR INSTALLATION INFORMATION

	SYMBOL	UNITS	NOMINAL ANCHOR DIAMETER (in.)					
			$1/4$		$3/8$		$1/2$	
Anchor outer diameter	$d_a$	in. (mm)	0.25 (6.4)		0.375 (9.5)		0.5 (12.7)	
Nominal carbide bit diameter	$d_{bit}$	in. (mm)	$1/4$		$3/8$		$1/2$	
Effective embedment depth	$h_{ef}$	in. (mm)	$1\frac{1}{2}$ (38)	2 (51)	$1\frac{3}{4}$ (44)	$2\frac{5}{8}$ (67)	$1\frac{7}{8}$ (48)	$3\frac{3}{8}$ (86)
Nominal Embedment depth	$h_{nom}$	in. (mm)	$1\frac{3}{4}$ (44)	$2\frac{1}{4}$ (57)	$2\frac{1}{4}$ (57)	$3\frac{1}{8}$ (79)	$2\frac{1}{2}$ (64)	4 (102)
Minimum hole depth	$h_o$	in. (mm)	2 (51)	$2\frac{1}{2}$ (64)	$2\frac{1}{2}$ (64)	$3\frac{3}{8}$ (86)	$2\frac{3}{4}$ (70)	$4\frac{1}{4}$ (108)
Minimum concrete member thickness	$h_{min}$	in. (mm)	4 (102)		4 (102)	5 (127)	5 (127)	6 (152)
Critical edge distance	$c_{ac}$	in. (mm)	$2\frac{5}{8}$ (67)	3 (76)	$2\frac{5}{8}$ (67)	$5\frac{1}{4}$ (133)	$3\frac{3}{4}$ (95)	$6\frac{3}{4}$ (171)
Minimum edge distance	$c_{min}$	in. (mm)	$1\frac{3}{4}$ (44)	$1\frac{1}{2}$ (38)	$2\frac{1}{4}$ (57)	2 (51)	$3\frac{3}{4}$ (95)	$3\frac{3}{4}$ (95)
Minimum anchor spacing	$s_{min}$	in. (mm)	$1\frac{3}{4}$ (44)	$1\frac{1}{2}$ (38)	$2\frac{1}{4}$ (57)	2 (51)	$3\frac{3}{4}$ (95)	$3\frac{3}{4}$ (95)
Installation torque	$T_{inst}$	ft-lb (N-m)	4 (5)		25 (34)		55 (75)	
Reference (attachment) hole diameter	$d_h$	in. (mm)	$\frac{5}{16}$ (7.9)		$\frac{7}{16}$ (11.1)		$\frac{9}{16}$ (14.3)	

TABLE 3—ITW TRUBOLT WEDGE ANCHOR DESIGN INFORMATION<sup>1,2,3</sup>

DESIGN INFORMATION	SYMBOL	UNITS	NOMINAL ANCHOR DIAMETER					
			$\frac{1}{4}$	$\frac{3}{8}$	$\frac{1}{2}$	$\frac{5}{8}$	$\frac{3}{4}$	$\frac{7}{8}$
Anchor O.D.	$d_o$	in	0.250		0.375		0.500	
		mm	6.4		9.5		12.7	
Effective min. embedment	$h_{ef}$	in	$1\frac{1}{2}$	2	$1\frac{3}{4}$	$2\frac{5}{8}$	$1\frac{7}{8}$	$3\frac{3}{8}$
		mm	38	51	44	67	48	86
Minimum member thickness	$h_{min}$	in	4	4	4	5	5	6
		mm	102	102	102	127	127	152
Installation Torque	$T_{inst}$	ft-lb	4		25		55	
		N-m	5		34		75	
Critical edge distance	$c_{ac}$	in	$2\frac{5}{8}$	3	$2\frac{5}{8}$	$5\frac{1}{4}$	$3\frac{3}{4}$	$6\frac{3}{4}$
		mm	67	76	67	133	95	171
Minimum edge distance	$c_{min}$	in	$1\frac{3}{4}$	$1\frac{1}{2}$	$2\frac{1}{4}$	2	$3\frac{3}{4}$	$3\frac{3}{4}$
		mm	44	38	57	51	95	95
Minimum anchor spacing	$s_{min}$	in	$1\frac{3}{4}$	$1\frac{1}{2}$	$2\frac{1}{4}$	2	$3\frac{3}{4}$	$3\frac{3}{4}$
		mm	44	38	57	51	95	95
Min. hole depth in concrete	$h_o$	in	2	$2\frac{1}{2}$	$2\frac{1}{2}$	$3\frac{3}{8}$	$2\frac{3}{4}$	$4\frac{1}{4}$
		mm	51	64	64	86	70	108
Min. Specified Yield Strength	$f_{ya}$	lb/in <sup>2</sup>	55,000					
		N/mm <sup>2</sup>	379					
Min. Specified Ultimate Strength	$f_{uta}$	lb/in <sup>2</sup>	75,000					
		N/mm <sup>2</sup>	517					
Effective tensile stress area	$A_{se,N}$	in <sup>2</sup>	0.032		0.078		0.142	
		mm <sup>2</sup>	20.5		50.0		91.5	
Effective shear stress area	$A_{se,V}$	in <sup>2</sup>	0.032		0.078		0.142	
		mm <sup>2</sup>	20.5		50.0		91.5	
Steel strength in tension	$N_{sa}$	lb	2385		5815		10645	
		kN	10.6		25.9		47.3	
Steel strength in shear	$V_{sa}$	lb	1430		2975	3490	4450	6385
		kN	6.4		13.2	15.5	19.8	28.4
Pullout strength, uncracked concrete	$N_{p,unscr}$	lb	See Table 4					
		kN						
Anchor Category			1					
Effectiveness factor $k_{unscr}$ uncracked concrete <sup>5</sup>			24					
Coefficient for pryout strength	$k_{cp}$	-	1.0	1.0	1.0	2.0	1.0	2.0
		lb/in	14,651	9,385	17,515	26,424	32,483	26,136
Axial stiffness in service load range	$\beta$	lb/in	14,651	9,385	17,515	26,424	32,483	26,136
		kN/mm	2.6	1.6	3.1	4.6	5.7	4.6
Coefficient of variation for axial stiffness in service load range			34	47	28	45	17	33
Strength reduction factor for tension, steel failure modes	$\phi$	—	0.75					
Strength reduction factor for shear, steel failure modes	$\phi$	—	0.65					
Strength reduction factor for tension, concrete failure modes, Condition B <sup>4</sup>	$\phi$	—	0.65					
Strength reduction factor for shear, concrete failure modes, Condition B <sup>4</sup>	$\phi$	—	0.70					

For SI: 1 inch = 25.4 mm, 1 lbf = 4.45 N, 1 psi = 0.006895 Mpa. For pound-inch units: 1 mm = 0.03937 inch.

<sup>1</sup>The data in this table is intended to be used with the design provisions of ACI 318-14 Chapter 17 or ACI 318-11 Appendix D, as applicable.

<sup>2</sup>Installation must comply with the manufacturers printed installation instructions and details, and this report.

<sup>3</sup>The Trubolt Wedge Anchors are ductile steel elements as defined by ACI 318-14 2.3 or ACI 318-11 D.1, as applicable.

<sup>4</sup>All values of  $\phi$  apply to the load combinations of IBC Section 1605.2, ACI 318-14 Section 5.3, or ACI 318-11 Section 9.2, as applicable. If the load combinations of ACI 318-11 Appendix C are used, then the appropriate value of  $\phi$  must be determined in accordance with ACI 318-11 D.4.4(c) (ACI 318-08 and -05 D.4.5(c)). For installations where reinforcement that complies with ACI 318-14 Chapter 17 or ACI 318-11 Appendix D requirements for Condition A is present, the appropriate  $\phi$  factor must be determined in accordance with ACI 318-14 17.3.3(c) or ACI 318-11 D.4.3(c) (ACI 318-08 and -05 D.4.4(c)).

<sup>5</sup>For all design cases  $\psi_{c,N} = 1.0$ . The appropriate effectiveness factor for cracked concrete ( $k_{cr}$ ) or uncracked concrete ( $k_{unscr}$ ) must be used.

TABLE 4—ITW TRUBOLT WEDGE ANCHOR PULLOUT STRENGTH,  $N_{p,uncr}$ <sup>1,2</sup>

NOMINAL ANCHOR DIAMETER (in.)	EFFECTIVE EMBEDMENT DEPTH (in.)	CONCRETE COMPRESSIVE STRENGTH			
		f'c = 2,500 psi	f'c = 3,000 psi	f'c = 4,000 psi	f'c = 6,500 psi
1/4	1 1/2	1,392	1,525	1,610	1,822
	2	1,706	1,869	1,947	2,151
3/8	1 3/4	2,198	2,408	2,621	3,153
	2 5/8	3,469	3,800	3,936	4,275
1/2	1 7/8	2,400	2,629	3,172	4,520
	3 3/8	4,168	4,520	4,520	4,520

For **SI**: 1 inch = 25.4 mm, 1 lbf = 4.45 N, 1 psi = 0.006895 MPa.

<sup>1</sup> Values are for single anchors with no edge distance or spacing reduction.

<sup>2</sup> Condition B applies where supplementary reinforcement in conformance with ACI 318-14 Chapter 17 or ACI 318-11 Appendix D is present, or where product pullout or pryout strength governs. For installations where reinforcement that complies with ACI 318-14 Chapter 17 or ACI 318-11 Appendix D requirements for Condition A is present, the appropriate  $\phi$  factor must be determined in accordance with ACI 318-14 17.3.3(c) or ACI 318-11 D.4.3(c) (ACI 318-08 and -05 D.4.4(c)).

TABLE 5—EXAMPLE RED HEAD TRUBOLT WEDGE ANCHOR ALLOWABLE STRESS DESIGN (ASD) VALUES FOR ILLUSTRATIVE PURPOSES<sup>1,2,3,4,5,6,7,8,9</sup>

NOMINAL ANCHOR DIAMETER (in.)	EFFECTIVE EMBEDMENT DEPTH (in.)	CONCRETE COMPRESSIVE STRENGTH			
		f'c = 2,500 psi	f'c = 3,000 psi	f'c = 4,000 psi	f'c = 6,500 psi
1/4	1 1/2	610	670	705	800
	2	750	820	855	945
3/8	1 3/4	965	1,060	1,150	1,385
	2 5/8	1,525	1,670	1,730	1,880
1/2	1 7/8	1,055	1,155	1,395	1,985
	3 3/8	1,830	1,985	1,985	1,985

For **SI**: 1 inch = 25.4 mm, 1 lbf = 4.45 N, 1 psi = 0.006895 MPa.

**Design assumptions:**

<sup>1</sup>Single anchor with static tension load only.

<sup>2</sup>Concrete determined to remain uncracked for the life of the anchorage.

<sup>3</sup>Load combinations are in accordance with ACI 318-14 Section 5.3 or ACI 318-11 Section 9.2, as applicable, and no seismic loading.

<sup>4</sup>30 percent dead load and 70 percent live load, controlling load combination  $1.2D + 1.6L$ .

<sup>5</sup>Calculation of weighted average for  $\alpha$ :  $1.2D + 1.6L = 1.2(0.3) + 1.6(0.7) = 1.48$ .

<sup>6</sup> $f'_c = 2,500$  psi (normal-weight concrete).

<sup>7</sup> $C_{a1} = C_{a2} > C_{ac}$ .

<sup>8</sup> $h \geq h_{min}$ .

<sup>9</sup>Values are for Condition B where supplementary reinforcement in accordance with ACI 318-14 17.3.3(c) or ACI 318-11 D.4.3(c), as applicable, is not provided.



**Illustrative Procedure to Calculate Allowable Stress Design Tension Value:**

RED HEAD Trubolt Wedge Anchor  $1\frac{1}{2}$  inch diameter using an effective embedment of  $3\frac{3}{8}$  inches, assuming the given conditions in Table 5 for  $f'_c = 2,500$  psi normal-weight concrete, in accordance with ACI 318-14 Chapter 17 and this report.

PROCEDURE		CALCULATION
Step 1	Calculate steel strength of a single anchor in tension per ACI 318-14 Section 17.4.1.2, Table 3 of this report	$\phi N_{sa} = \phi N_{sa}$ $= 0.75 * 10,645$ $= 7,984 \text{ lb (steel strength)}$
Step 2	Calculate concrete breakout strength of a single anchor in tension per ACI 318-14 Section 17.4.2.1, Table 3 of this report	$N_b = 7,440 \text{ lbs}$  $\phi N_{cb} = \phi A_{NC} / A_{NC0} \psi_{ed,N} \psi_{c,N} \psi_{cp,N} N_b$ $= 0.65 * (103/103) * 1.0 * 1.0 * 1.0 * 7,440$ $= 0.65 * 7,440$ $= 4,836 \text{ lb (concrete breakout strength)}$
Step 3	Calculate pullout strength in tension per ACI 318-14 Section 17.4.3.2 and Table 5 of this report	$\phi N_{pn} = \phi N_{p,uncr}$ $= 0.65 * 4,168$ $= 2,709 \text{ lb (pullout strength)}$
Step 4	Determine controlling resistance strength in tension per ACI 318-14 Section 17.3.1.1	<b>= 2,709 lb (controlling resistance)</b>
Step 5	Calculate allowable stress design conversion factor for loading condition per ACI 318-14 Section 5.3:	$\alpha = 1.2D + 1.6L$ $= 1.2(0.3) + 1.6(0.7)$ $= 1.48$
Step 6	Calculate allowable stress design value per Section 4.2 of this report	$T_{allowable,ASD} = \phi N_n / \alpha$ $= 2,709 / 1.48$ $= 1,830 \text{ lb (allowable stress design)}$

**FIGURE 4—DESIGN EXAMPLE**

## ICC-ES Evaluation Report

## ESR-2251 FBC Supplement

Reissued September 2019

This report is subject to renewal September 2021.

[www.icc-es.org](http://www.icc-es.org) | (800) 423-6587 | (562) 699-0543

A Subsidiary of the International Code Council®

**DIVISION: 03 00 00—CONCRETE**

**Section: 03 16 00—Concrete Anchors**

**DIVISION: 05 00 00—METALS**

**Section: 05 05 19—Post-Installed Concrete Anchors**

**REPORT HOLDER:**

**ITW RED HEAD**

**EVALUATION SUBJECT:**

**ITW RED HEAD TRUBOLT CARBON STEEL WEDGE ANCHORS IN CONCRETE**

### 1.0 REPORT PURPOSE AND SCOPE

**Purpose:**

The purpose of this evaluation report supplement is to indicate that the RED HEAD Trubolt Wedge Anchors, recognized in ICC-ES master evaluation report ESR-2251, has also been evaluated for compliance with the codes noted below.

**Applicable code editions:**

- 2017 *Florida Building Code—Building*
- 2017 *Florida Building Code—Residential*

### 2.0 CONCLUSIONS

The RED HEAD Trubolt Wedge Anchors, described in Sections 2.0 through 7.0 of the master evaluation report ESR-2251, comply with the *Florida Building Code—Building* and the *Florida Building Code—Residential*, when designed and installed in accordance with the 2015 *International Building Code*® provisions noted in the master report.

Use of the RED HEAD Trubolt Wedge Anchors for compliance with the High-Velocity Hurricane Zone Provisions of the *Florida Building Code—Building* and the *Florida Building Code—Residential* has not been evaluated and is outside the scope of this supplement.

For products falling under Florida Rule 9N-3, verification that the report holder's quality-assurance program is audited by a quality-assurance entity approved by the Florida Building Commission for the type of inspections being conducted is the responsibility of an approved validation entity (or the code official, when the report holder does not possess an approval by the Commission).

This supplement expires concurrently with the master report, reissued September 2019.