



ICC-ES Evaluation Report

ESR-4046

Reissued September 2021

This report is subject to renewal September 2022.

DIVISION: 03 00 00—CONCRETE

Section: 03 16 00—Concrete Anchors

DIVISION: 05 00 00—METALS

Section: 05 05 19—Post-Installed Concrete Anchors

REPORT HOLDER:

ITW RED HEAD

EVALUATION SUBJECT:

ITW RED HEAD C6+ ADHESIVE ANCHORING SYSTEM FOR CRACKED AND UNCRACKED CONCRETE

1.0 EVALUATION SCOPE

Compliance with the following codes:

- 2015, 2012, 2009, 2006 and 2003 *International Building Code*® (IBC)
- 2015, 2012, 2009, 2006 and 2003 *International Residential Code*® (IRC)

For evaluation for compliance with codes adopted by the Los Angeles Department of Building and Safety (LADBS), see [ESR-4046 LABC and LARC Supplement](#).

Property evaluated:

Structural

2.0 USES

Adhesive anchors installed using the Red Head C6+ Adhesive Anchoring System are post-installed adhesive anchors used to resist static, wind or earthquake (for use in structures assigned to Seismic Design Categories A through F) tension and shear loads in cracked and uncracked normalweight concrete, having a specified compressive strength, f'_c , of 2500 psi to 8,500 psi (17.2 MPa to 58.6 MPa).

The anchoring system complies with requirements for anchors as described in Section 1901.3 of the 2015 IBC, Section 1909 of the 2012 IBC and is an alternative to cast-in-place anchors described in Section 1908 of the 2012 IBC, and Sections 1911 and 1912 of the 2009 and 2006 IBC, and Sections 1912 and 1913 of the 2003 IBC. The adhesive anchoring system may also be used where an engineered design is submitted in accordance with Section R301.1.3 of the IRC.

3.0 DESCRIPTION

3.1 General:

The Red Head C6+ Adhesive Anchoring System consists of a two-component, high-strength, structural adhesive, an anchor element (a continuously threaded steel rod or a deformed steel reinforcing bar) installed in normalweight concrete, hole cleaning equipment, adhesive dispensing tools, and installation accessories. The primary components of the Red Head C6+ Adhesive Anchoring System supplied by the report holder are shown in Figure 1 of this report.

The manufacturer's printed installation instructions (MPII) are included with the adhesive packaging and are replicated in Figure 3 of this report.

3.2 Materials:

3.2.1 Red Head C6+ Adhesive: The primary component of the Red Head C6+ Adhesive Anchoring System is a two-part epoxy packaged in a dual-chamber cartridge at a volumetric ratio of 2:1. The cartridge is available in 30-ounce (side-by-side) or 15-ounce (side-by-side) sizes. The adhesive components are dispensed through a static mixing nozzle, supplied by ITW, which is attached to the cartridge. The original, unopened cartridge has a shelf life of 24 months, as indicated by the "best used by" date stamped onto the cartridge, when stored in a cool (50°F to 77°F), dry, ventilated area and in accordance with Figure 3.

3.2.2 Hole Cleaning Equipment and Installation Accessories: Hole cleaning equipment consists of wire brushes, as shown in Figures 1 and 3, and a compressed air nozzle with extension. Installation accessories include static mixing nozzles, extension tubing, piston plugs, and hole plugs as shown in Figures 1 and 3.

3.2.3 Dispensing Tools: Red Head C6+ Adhesive must be dispensed with manual or pneumatic or battery-operated dispensing tools provided by ITW Red Head, as shown in Figure 1.

3.2.4 Anchor Elements:

3.2.4.1 Steel Threaded Rods: The continuously threaded steel rods must range from $\frac{3}{8}$ inch through $1\frac{1}{4}$ inches (9.5 mm through 31.75 mm) in diameter. Carbon steel threaded rods must comply with either ASTM A36 [minimum f_{uta} = 58,000 psi (400 MPa)] or ASTM A193,

Grade B7 [minimum $f_{uta} = 125,000$ psi (860 MPa)]. Stainless steel threaded rods must comply with ASTM F593 (Alloy Type 300, CW1 and CW2) [minimum $f_{uta} = 95,000$ psi (655 MPa) for CW1, and $f_{uta} = 80,000$ psi (552 MPa) for CW2]. Table 1 provides steel design information for the steel threaded rods. Carbon steel threaded rods must be furnished with a minimum 0.0002-inch-thick (5 μm) zinc electroplated coating complying with ASTM B633 SC1 or must be hot-dipped galvanized complying with ASTM A153, Class C or D. Steel grades, types of materials (carbon steel or stainless steel) and sizes of the washers and nuts must match the corresponding threaded rods. Threaded steel rods must be straight and free from indentations or other defects along their length.

3.2.4.2 Steel Reinforcing Bars: Steel reinforcing bars must be deformed reinforcing bars as described in Table 5 of this report. The embedded portions of reinforcing bars must be straight, and free of mill scale, rust, mud, oil, and other coatings that may impair the bond with the adhesive. Reinforcing bars must not be bent after installation, except as set forth in ACI 318-14 Section 26.6.3.1 (b) or ACI 318-11 Section 7.3.2, as applicable, with the additional condition that the bars must be bent cold, and heating of reinforcing bars to facilitate field bending is not permitted.

3.2.4.3 Ductility of Anchor Elements: In accordance with ACI 318-14 Section 2.3 or ACI 318-11 Appendix D Section D.1, as applicable, in order for a steel anchor element to be considered ductile, the tested elongation of the steel element must be at least 14 percent and reduction of area must be at least 30 percent. Steel elements with a tested elongation of less than 14 percent or a reduction of area of less than 30 percent, or both, are considered brittle. Strength reduction factors, ϕ , in Table 1 for ASTM A36 and ASTM A193 B7 steel threaded rods are applicable to ductile steel elements; values in Table 1 for ASTM F593 steel threaded rod are applicable to brittle steel elements; values in Table 5 for ASTM A615 Grade 60 steel reinforcing bars are applicable to brittle steel elements. Where values are nonconforming or unstated, the steel must be considered brittle.

3.3 Concrete:

Normalweight concrete must comply with Sections 1903 and 1905 of the IBC. The specified compressive strength of the concrete must be from 2,500 psi to 8,500 psi (17.2 MPa to 58.6 MPa).

4.0 DESIGN AND INSTALLATION

4.1 Strength Design:

4.1.1 General: The design strength of adhesive anchors under the 2015 IBC, as well as the 2015 IRC must be determined in accordance with ACI 318-14 and this report. The design strength of adhesive anchors under the 2012, 2009, 2006 and 2003 IBC, as well as the 2012, 2009, 2006 and 2003 IRC, must be determined in accordance with ACI 318-11 and this report.

A design example in accordance with the 2012 IBC based on ACI 318-11 is provided in Figure 2 of this report.

Design parameters are based on ACI 318-14 for use with the 2015 IBC, and the ACI 318-11 for use with the 2012, 2009, 2006 and 2003 IBC unless noted otherwise in this report. In keeping consistent with ACI 318 notation style, the word “Section” does not precede ACI 318 Section numbers in Sections 4 and 5 of this report.

The strength design of adhesive anchors must comply with ACI 318-14 17.3.1 or ACI 318-11 D.4.1, as applicable,

except as required in ACI 318-14 17.2.3 or ACI 318-11 D.3.3, as applicable. Design parameters are provided in Tables 1 through 6. Strength reduction factors, ϕ , as given in ACI 318-14 17.3.3 or ACI 318-11 D.4.3, as applicable, must be used for load combinations calculated in accordance with Section 1605.2 of the IBC or ACI 318-14 5.3 or ACI 318-11 9.2, as applicable. Strength reduction factors, ϕ , as described in ACI 318-11 D.4.4, must be used for load combinations calculated in accordance with ACI 318-11 Appendix C.

4.1.2 Static Steel Strength in Tension: The nominal static steel strength of a single anchor in tension, N_{sa} , in accordance with ACI 318-14 17.4.1.2 or ACI 318-11 D.5.1.2, as applicable, and the associated strength reduction factors, ϕ , in accordance with ACI 318-14 17.3.3 or ACI 318-11 D.4.3, as applicable, are given in Tables 1 and 5 of this report for the anchor element types included in this report.

4.1.3 Static Concrete Breakout Strength in Tension: The nominal static concrete breakout strength of a single anchor or group of anchors in tension, N_{cb} or N_{cbg} , must be calculated in accordance with ACI 318-14 17.4.2 or ACI 318-11 D.5.2, as applicable, with the following addition:

The basic concrete breakout strength of a single anchor in tension, N_b , must be calculated in accordance with ACI 318-14 17.4.2.2 or ACI 318-11 D.5.2.2, as applicable, using the values of $K_{c,cr}$, and $K_{c,un-cr}$ as described in Tables 2 and 6 of this report. Where analysis indicates no cracking in accordance with ACI 318-14 17.4.2.6 or ACI 318-11 D.5.2.6, as applicable, N_b must be calculated using $K_{c, un-cr}$ and $\Psi_{c,N} = 1.0$. For anchors in lightweight concrete see ACI 318-14 17.2.6 or ACI 318-11 D.3.6, as applicable. The value of f'_c used for calculation must be limited to 8,000 psi (55 MPa) in accordance with ACI 318-14 17.2.7 or ACI 318-11 D.3.7, as applicable. Additional information for the determination of nominal bond strength in tension is given in Section 4.1.4 of this report.

4.1.4 Static Bond Strength in Tension: The nominal static bond strength of a single adhesive anchor or group of adhesive anchors in tension, N_a or N_{ag} , must be calculated in accordance with ACI 318-14 17.4.5 or ACI 318-11 D.5.5, as applicable. Bond strength values are a function of whether the concrete is cracked or uncracked, the concrete temperature range, the installation conditions (dry or water-saturated concrete, water-filled holes, or submerged), and the level of inspection provided. The resulting characteristic bond strength must be multiplied by the associated strength reduction factor ϕ_{bn} as follows:

CONCRETE TYPE	PERMISSIBLE INSTALLATION CONDITIONS	BOND STRENGTH	ASSOCIATED STRENGTH REDUCTION FACTOR
Uncracked	Dry	τ_{un-cr}	ϕ_d
	Water-saturated	τ_{un-cr}	ϕ_{ws}
	Water-filled holes	τ_{un-cr}	ϕ_{wf}
	Submerged	τ_{un-cr}	ϕ_{sub}
Cracked	Dry	τ_{cr}	ϕ_d
	Water-saturated	τ_{cr}	ϕ_{ws}
	Water-filled holes	τ_{cr}	ϕ_{wf}
	Submerged	τ_{cr}	ϕ_{sub}

Strength reduction factors for determination of the bond strength are given in Tables 3, 4, 7 and 8 of this report.

4.1.5 Static Steel Strength in Shear: The nominal static strength of a single anchor in shear as governed by the steel, V_{sa} , in accordance with ACI 318-14 17.5.1.2 or ACI 318-11 D.6.1.2, as applicable, and strength reduction factors, ϕ , in accordance with ACI 318-14 17.2.3 or ACI 318-11 D.4.3, as applicable are given in Tables 1 and 5 of this report for the anchor element types included in this report.

4.1.6 Static Concrete Breakout Strength in Shear: The nominal concrete breakout strength of a single anchor or group of anchors in shear, V_{cb} or V_{cbg} , must be calculated in accordance with ACI 318-14 17.5.2 or ACI 318-11 D.6.2, as applicable, based on information given in Table 2 and Table 6 of this report. The basic concrete breakout strength of a single anchor in shear, V_b , must be calculated in accordance with ACI 318-14 17.5.2.2 or ACI 318-11 D.6.2.2, as applicable, using the values of d given in this report in lieu of d_a (2015, 2012 and 2009 IBC), d_o (2006 IBC). In addition, h_{ef} must be substituted for ℓ_e . In no case shall ℓ_e exceed $8d$. The value of f'_c must be limited to a maximum value of 8,000 psi (55 MPa) in accordance with ACI 318-14 17.2.7 or ACI 318-11 D.3.7, as applicable.

4.1.7 Static Concrete Pryout Strength in Shear: The nominal static pryout strength of a single anchor or group of anchors in shear, V_{cp} or V_{cpg} , shall be calculated in accordance with ACI 318-14 17.5.3 or ACI 318-11 D.6.3, as applicable.

4.1.8 Interaction of Tensile and Shear Forces: For designs that include combined tension and shear, the interaction of tension and shear loads must be calculated in accordance with ACI 318-14 17.6 or ACI 318-11 D.7, as applicable.

4.1.9 Minimum Member Thickness, h_{min} , Anchor Spacing, s_{min} , and Edge Distance, c_{min} : In lieu of ACI 318-14 17.7.1 and 17.7.3 or ACI 318-11 D.8.1 and D.8.3, as applicable, values of s_{min} and c_{min} , as given in Table 2 and Table 6 of this report, must be observed for adhesive anchor design and installation. The minimum member thicknesses h_{min} , as given in Table 2 and Table 6 of this report must be observed for adhesive anchor design and installation. For adhesive anchors that will remain untorqued, ACI 318-14 17.7.4 or ACI 318-11 D.8.4, as applicable, applies.

4.1.10 Critical Edge Distance c_{ac} and $\psi_{cp,Na}$: The modification factor $\psi_{cp,Na}$, must be determined in accordance with ACI 318-14 17.4.5.5 or ACI 318-11 D.5.5.5, as applicable, except as noted below:

For all cases where $c_{Na}/c_{ac} < 1.0$, $\psi_{cp,Na}$ determined from ACI 318-14 Eq. 17.4.5.5b or ACI 318-11 Eq. D-27, as applicable, need not be taken less than c_{Na}/c_{ac} . For all other cases, $\psi_{cp,Na}$ shall be taken as 1.0.

The critical edge distance, c_{ac} must be calculated according to Eq. 17.4.5.5c for ACI 318-14 or Eq. D-27a for ACI 318-11, in lieu of ACI 318-14 17.7.6 or ACI 318-11 D.8.6, as applicable.

$$c_{ac} = h_{ef} \left(\frac{\tau_{k,uncr}}{1160} \right)^{0.4} \cdot \left[3.1 - 0.7 \frac{h}{h_{ef}} \right]$$

(Eq. 17.4.5.5c for ACI 318-14 or Eq. D-27a for ACI 318-11)

where

$\left[\frac{h}{h_{ef}} \right]$ need not be taken as larger than 2.4; and

$\tau_{k,uncr}$ = the characteristic bond strength stated in the tables of this report whereby $\tau_{k,uncr}$ need not be taken as larger than:

$$\tau_{uncr} = \frac{k_{uncr} \sqrt{h_{ef} f'_c}}{\pi \cdot d_a} \quad \text{Eq. (4-1)}$$

4.1.11 Design Strength in Seismic Design Categories C, D, E and F:

In structures assigned to Seismic Design Category C, D, E or F under the IBC or IRC, anchors must be designed in accordance with ACI 318-14 17.2.3 or ACI 318-11 D.3.3, as applicable, except as described below. Modifications to ACI 318-14 17.2.3 shall be applied under Section 1905.1.8 of the 2015 IBC. For the 2012 IBC, Section 1905.1.9 shall be omitted. The nominal steel shear strength, V_{sa} , must be adjusted by $\alpha_{V,seis}$ as given in Tables 1 and 5 for the anchor element types included in this report. The nominal bond strength $\tau_{k,cr}$ must be adjusted by $\alpha_{N,seis}$, as given in Tables 3, 4, 7 and 8 of this report.

As an exception to ACI 318-11 D.3.3.4.2: Anchors designed to resist wall out-of-plane forces with design strengths equal to or greater than the force determined in accordance with ASCE 7 Equation 12.11-1 or 12.14-10 shall be deemed to satisfy ACI 318-11 D.3.3.4.3(d).

Under ACI 318-11 D.3.3.4.3(d), in lieu of requiring the anchor design tensile strength to satisfy the tensile strength requirements of ACI 318-11 D.4.1.1, the anchor design tensile strength shall be calculated from ACI 318-11 D.3.3.4.4.

The following exceptions apply to ACI 318-11 D.3.3.5.2:

1. For the calculation of the in-plane shear strength of anchor bolts attaching wood sill plates of bearing or non-bearing walls of light-frame wood structures to foundations or foundation stem walls, the in-plane shear strength in accordance with ACI 318-11 D.6.2 and D.6.3 need not be computed and ACI 318-11 D.3.3.5.3 need not apply provided all the following are satisfied:

1.1. The allowable in-plane shear strength of the anchor is determined in accordance with AF&PA NDS Table 11E for lateral design values parallel to grain.

1.2. The maximum anchor nominal diameter is $5/8$ inch (16 mm).

1.3. Anchor bolts are embedded into concrete a minimum of 7 inches (178 mm).

1.4. Anchor bolts are located a minimum of $1\ 3/4$ inches (45 mm) from the edge of the concrete parallel to the length of the wood sill plate.

1.5. Anchor bolts are located a minimum of 15 anchor diameters from the edge of the concrete perpendicular to the length of the wood sill plate.

1.6. The sill plate is 2-inch or 3-inch nominal thickness.

2. For the calculation of the in-plane shear strength of anchor bolts attaching cold-formed steel track of bearing or non-bearing walls of light-frame construction to foundations or foundation stem walls, the in-plane shear strength in accordance with ACI 318-11 D.6.2 and D.6.3 need not be computed and ACI 318-11 D.3.3.5.3 need not apply provided all the following are satisfied:

2.1. The maximum anchor nominal diameter is $5/8$ inch (16 mm).

2.2. Anchors are embedded into concrete a minimum of 7 inches (178 mm).

2.3. Anchors are located a minimum of $1\ 3/4$ inches

(45 mm) from the edge of the concrete parallel to the length of the track.

2.4. Anchors are located a minimum of 15 anchor diameters from the edge of the concrete perpendicular to the length of the track.

2.5. The track is 33 to 68 mil designation thickness.

Allowable in-plane shear strength of exempt anchors, parallel to the edge of concrete shall be permitted to be determined in accordance with AISI S100 Section E3.3.1.

3. In light-frame construction, bearing or nonbearing walls, shear strength of concrete anchors less than or equal to 1 inch [25 mm] in diameter attaching a sill plate or track to foundation or foundation stem wall need not satisfy ACI 318-11 D.3.3.5.3(a) through (c) when the design strength of the anchors is determined in accordance with ACI 318-11 D.6.2.1(c).

4.2 Allowable Stress Design:

4.2.1 General: For adhesive anchors designed using load combinations in accordance with IBC Section 1605.3 (Allowable Stress Design), allowable loads shall be established using Eq. (4-2) or Eq. (4-3):

$$T_{allowable,ASD} = \frac{\phi N_n}{\alpha} \quad \text{Eq. (4-2)}$$

and

$$V_{allowable,ASD} = \frac{\phi V_n}{\alpha} \quad \text{Eq. (4-3)}$$

where

$T_{allowable,ASD}$ = Allowable tension load (lbf or kN)

$V_{allowable,ASD}$ = Allowable shear load (lbf or kN)

ϕN_n = Lowest design strength of an anchor or anchor group in tension as determined in accordance with ACI 318-14 Chapter 17 and 2015 IBC Section 1905.1.8, ACI 318-11 Appendix D, ACI 318-08 Appendix D and 2009 IBC Sections 1908.1.9 and 1908.1.10, ACI 318-05 Appendix D and 2006 IBC Section 1908.1.16, and Section 4.1 of this report, as applicable.

ϕV_n = Lowest design strength of an anchor or anchor group in shear as determined in accordance with ACI 318-14 Chapter 17 and 2015 IBC Section 1905.1.8, ACI 318-11 Appendix D, ACI 318-08 Appendix D and 2009 IBC Sections 1908.1.9 and 1908.1.10, ACI 318-05 Appendix D and 2006 IBC Section 1908.1.16, and Section 4.1 of this report, as applicable.

α = Conversion factor calculated as a weighted average of the load factors for the controlling load combination. In addition, α must include all applicable factors to account for non-ductile failure modes and required over-strength.

Limits on edge distance, anchor spacing and member thickness described in this report must apply.

Example calculations for derivation of $T_{allowable,ASD}$ are provided in Figure 2 and Table 9.

4.2.2 Interaction of tensile and shear forces: In lieu of ACI 318-14 17.6.1, 17.6.2 and 17.6.3 or ACI 318-11 D.7.1, D.7.2 and D.7.3, as applicable, interaction must be calculated as follows:

For shear loads $V \leq 0.2V_{allowable,ASD}$, the full allowable load in tension shall be permitted.

For tension loads $T \leq 0.2T_{allowable,ASD}$, the full allowable load in shear shall be permitted.

For all other cases:

$$\frac{T}{T_{allowable,ASD}} + \frac{V}{V_{allowable,ASD}} \leq 1.2 \quad \text{Eq. (4-4)}$$

4.3 Installation:

Installation parameters are illustrated in Figure 3 of this report. Installation must be in accordance with ACI 318-14 17.8.1 and 17.8.2 or ACI 318-11 D.9.1 and D.9.2, as applicable. Adhesive anchor locations must comply with this report and the plans and specifications approved by the code official. Use of the Red Head C6+ Adhesive Anchoring System must conform to the manufacturer's printed installation instructions included in each unit package, as provided in Figure 3 of this report.

The adhesive anchors may be used for floor (vertically down), wall (horizontal) and overhead applications. Horizontal and overhead applications are to be used with the $\frac{3}{8}$ -inch (9.5 mm) through $1\frac{1}{4}$ -inch-diameter (31 mm) threaded rods and reinforcing bars. For the $\frac{3}{8}$ -inch diameter (9.5 mm) and $\frac{1}{2}$ -inch diameter (12 mm), the adhesive may be injected directly to the bottom/back of the hole using extension tubing or nozzle. The $\frac{5}{8}$ -inch (16 mm) through $1\frac{1}{4}$ -inch (31 mm) diameter threaded rod and reinforcing bars must be installed with a Red Head piston plug.

4.4 Special Inspection:

4.4.1 General: Installations may be made under continuous special inspection or periodic special inspection, as determined by the registered design professional. Tables 3, 4, 7 and Table 8 of this report provide strength reduction factors, ϕ , corresponding to the type of inspection provided.

Continuous special inspection of adhesive anchors installed in horizontal or upwardly inclined orientations to resist sustained tension loads shall be performed in accordance with ACI 318-14 17.8.2.4 or ACI 318-11 D.9.2.4, as applicable.

Under the IBC, additional requirements as set forth in Section 1705.1.1 and Table 1705.3 of the 2015 or 2012 IBC, and Sections 1705, 1706 or 1707 of the 2009, 2006, and 2003 IBC must be observed, where applicable.

4.4.2 Continuous Special Inspection: Installations made under continuous special inspection with an on-site proof loading program must be performed in accordance with Section 1705.1.1 and Table 1705.3 of the 2015 and 2012 IBC, Sections 1704.4 and 1704.15 and Table 1704.4 of the 2009 IBC, or Section 1704.13 of the 2006 and 2003 IBC, whereby continuous special inspection is defined in Section 1702.1 of the IBC, and this report. The special inspector must be on the jobsite continuously during anchor installation to verify anchor type, adhesive expiration date, anchor dimensions, concrete type, concrete compressive strength, hole dimensions, hole cleaning procedures, anchor spacing, edge distances, concrete thickness, anchor embedment, tightening torque, and adherence to the manufacturers printed installation instructions.

The proof loading program must be established by the registered design professional. As a minimum, the following requirements must be addressed in the proof loading program:

1. Frequency of proof loading based on anchor type, diameter, and embedment.
2. Proof loads by anchor type, diameter, embedment, and location.
3. Acceptable displacements at proof load.

4. Remedial action in the event of a failure to achieve proof load, or excessive displacement.

Unless otherwise directed by the registered design professional, proof loads must be applied as confined tension tests. Proof load levels must not exceed the lesser of 67 percent of the load corresponding to the nominal bond strength as calculated from the characteristic bond stress for uncracked concrete modified for edge effects and concrete properties, or 80 percent of the minimum specified anchor element yield strength ($A_{se,N} \cdot f_{ya}$). The proof load shall be maintained at the required load level for a minimum of 10 seconds.

4.4.3 Periodic Special Inspection: Periodic special inspection must be performed where required in accordance with Section 1705.1.1 and Table 1705.3 of the 2015 and 2012 IBC, Section 1704.15 and Table 1704.4 of the 2009 IBC, or Section 1704.13 of the 2006, and 2003 IBC, whereby periodic special inspection is defined in Section 1702.1 of the IBC and this report. The special inspector must be on the jobsite initially during anchor installation to verify anchor type, anchor dimensions, concrete type, concrete compressive strength, hole dimensions, hole cleaning procedures, anchor spacing, edge distances, concrete thickness, anchor embedment, tightening torque, and adherence to the manufacturer's printed installation instructions. The special inspector must verify the initial installations of each type and size of adhesive anchor by construction personnel on the site. Subsequent installations of the same anchor type and size

by the same construction personnel are permitted to be performed in the absence of the special inspector. Any change in the anchor product being installed or the personnel performing the installation requires an initial inspection. For ongoing installations over an extended period, the special inspector must make regular inspections to confirm correct handling and installation of the product.

4.5 Compliance with NSF/ANSI Standard 61:

The Red Head C6+ Adhesive Anchoring System complies with the requirements of NSF/ANSI Standard 61, as referenced in Section 605 of the 2009 and 2006 *International Plumbing Code*® (IPC). Certified for use at a maximum surface area to volume ratio of 0.0005 square inches per liter in a tank. An NSF/ANSI Standard 61 listing is provided by NSF International.

5.0 CONDITIONS OF USE

Adhesive anchors installed using the Red Head C6+ Adhesive Anchoring System described in this report comply with or are a suitable alternative to what is specified in, those codes listed in Section 1.0 of this report, subject to the following conditions:

- 5.1 The Red Head C6+ adhesive anchors must be installed in accordance with the manufacturer's printed installation instructions, as included with the adhesive packaging and reproduced in Figure 3 of this report.
- 5.2 The adhesive anchors must be installed in cracked and uncracked normalweight concrete having a specified compressive strength of $f'_c = 2,500$ psi to 8,500 psi (17.2 MPa to 58.6 MPa).
- 5.3 The values of f'_c used for calculation purposes must not exceed 8,000 psi (55 MPa).
- 5.4 The concrete shall have attained its minimum design strength prior to installation of the adhesive anchors.
- 5.5 Adhesive anchors must be installed in concrete base materials in holes predrilled in accordance with the

instructions provided in Figure 3 of this report, using a carbide-tipped masonry drill bit manufactured within the range of the maximum and minimum drill-tip dimensions of ANSI B212.15-1994, or a diamond core drill bit, as listed in Figure 3.

- 5.6 Loads applied to the adhesive anchors must be adjusted in accordance with Section 1605.2 of the IBC for strength design and in accordance with Section 1605.3 of the IBC for allowable stress design.
- 5.7 Red Head C6+ adhesive anchors are recognized for use in resisting short- and long-term loads, including wind and earthquake loads, subject to the conditions of this report.
- 5.8 In structures assigned to Seismic Design Category C, D, E or F under the IBC or IRC, anchor strength must comply with the requirements of Section 4.1.11 of this report.
- 5.9 Red Head C6+ Adhesive Anchors are permitted to be installed in concrete that is cracked or that may be expected to crack during the service life of the anchor, subject to the conditions of this report.
- 5.10 Strength design values must be established in accordance with Section 4.1 of this report.
- 5.11 Allowable stress design values must be established in accordance with Section 4.2 of this report.
- 5.12 Minimum anchor spacing and edge distance, as well as minimum member thickness, must comply with the values given in this report.
- 5.13 Prior to adhesive anchor installation, calculations and details demonstrating compliance with this report must be submitted to the code official. The calculations and details must be prepared by a registered design professional where required by the statutes of the jurisdiction in which the project is to be constructed.
- 5.14 Adhesive anchors are not permitted to support fire-resistive construction. Where not otherwise prohibited by the code, adhesive anchors are permitted for installation in fire-resistive construction provided at least one of the following conditions is fulfilled:
 - Adhesive anchors are used to resist wind or seismic forces only.
 - Adhesive anchors that support gravity load-bearing structural elements are within a fire-resistive envelope or a fire-resistive membrane, are protected by approved fire-resistive materials, or have been evaluated for resistance to fire exposure in accordance with recognized standards.
 - Adhesive anchors are used to support nonstructural elements.
- 5.15 Since an ICC-ES acceptance criteria for evaluating data to determine the performance of adhesive anchors subjected to fatigue or shock loading is unavailable at this time, the use of these anchors under such conditions is beyond the scope of this report.
- 5.16 Use of zinc-plated carbon steel threaded rods or steel reinforcing bars as anchor elements is limited to dry, interior locations.

- 5.17 Use of hot-dipped galvanized carbon steel rods and stainless steel rods as anchor elements is permitted for exterior exposure or damp environments.
- 5.18 Steel anchoring elements in contact with preservative-treated and fire-retardant-treated wood must be of zinc-coated carbon steel or stainless steel. The minimum coating weights for zinc-coated steel must comply with ASTM A153.
- 5.19 Special inspection must be provided in accordance with Section 4.4 of this report. Continuous special inspection for anchors installed in horizontal or upwardly inclined orientations to resist sustained tension loads must be provided in accordance with Section 4.4 of this report.
- 5.20 Installation of adhesive anchors in horizontal or upwardly inclined orientations to resist sustained tension loads shall be performed by personnel certified by an applicable certification program in accordance with ACI 318-14 17.8.2.2 or 17.8.2.3; or ACI 318-11 D.9.2.2 or D.9.2.3, as applicable.
- 5.21 Red Head C6+ Adhesive Anchors may be used to resist tension and shear forces for floor (vertically down), wall (horizontal) and overhead installations with concrete temperatures between 50°F and 110°F. Horizontal and overhead applications are to be used with the 3/8-inch- (9.5 mm) through 1 1/4-inch-diameter (31 mm) threaded rods and reinforcing bars. The adhesive must be injected directly to the back end of the hole using extension tubing (E916-6) for the 1/2-inch-diameter anchors, and extension tubing (E25-6) for the 3/8-inch-diameter anchors. The 5/8-inch- (16 mm) through 1 1/4-inch-diameter (31 mm) threaded rod and reinforcing bars must be installed with a Red Head piston plug. See the MPII in Figure 3 of this report for temperature and installation requirements.

5.22 The Red Head C6+ Adhesive Anchoring System may not be used for applications where the concrete temperature can rise from 40°F (or less) to 80°F (or higher) within a 12-hour period. Such applications may include but are not limited to anchorage of building facade systems and other applications subject to direct sun exposure.

5.23 Red Head C6+ Adhesive is manufactured under a quality-control program with inspections by ICC-ES.

6.0 EVIDENCE SUBMITTED

Data in accordance with the ICC-ES Acceptance Criteria for Post-installed Adhesive Anchors in Concrete Elements (AC308), dated October 2016, which incorporates requirements in ACI 355.4-11.

7.0 IDENTIFICATION

7.1 Red Head C6+ Adhesive is identified by labels on the adhesive cartridges bearing the adhesive manufacturer’s name (ITW Commercial Construction North America) and address (Glendale Heights, Illinois), the product name (Red Head C6+), best-used-by expiration date, and the evaluation report number (ESR-4046).

7.2 The report holder’s contact information is the following:

ITW RED HEAD
700 HIGH GROVE BOULEVARD
GLENDALE HEIGHTS, ILLINOIS 60139
(800) 848-5611
www.itw-redhead.com
techsupport@itwccna.com



FIGURE 1—RED HEAD C6+ ADHESIVE CARTRIDGES, DISPENSING TOOLS, MIXING NOZZLES, HOLE CLEANING BRUSHES AND HOLE PLUGS

TABLE 1—STEEL DESIGN INFORMATION FOR U.S. CUSTOMARY UNIT STEEL THREADED ROD ⁽¹⁾

CHARACTERISTIC	SYMBOL	UNITS	NOMINAL ROD DIAMETER (inch)							
			$\frac{3}{8}$	$\frac{1}{2}$	$\frac{5}{8}$	$\frac{3}{4}$	$\frac{7}{8}$	1	1 $\frac{1}{4}$	
Threaded rod effective cross-sectional area	A_{se}	inch ²	0.078	0.142	0.226	0.335	0.462	0.606	0.969	
Carbon Steel A36	Nominal steel strength in tension	N_{sa}	lb	4,500	8,230	13,110	19,400	26,780	35,130	56,210
	Nominal steel strength in shear	V_{sa}	lb	2,700	4,940	7,870	11,640	16,070	21,080	33,730
	Strength reduction factor for tension, steel failure mode	ϕ	-	0.75	0.75	0.75	0.75	0.75	0.75	0.75
	Strength reduction factor for shear, steel failure mode ¹	ϕ	-	0.65	0.65	0.65	0.65	0.65	0.65	0.65
	Reduction factor for seismic shear	$\alpha_{V,seis}$	-	0.70	0.70	0.70	0.70	0.70	0.70	0.70
Carbon Steel A193 B7	Nominal steel strength in tension	N_{sa}	lb	9,690	17,740	28,250	41,810	57,710	75,710	121,140
	Nominal steel strength in shear	V_{sa}	lb	5,810	10,640	16,950	25,090	34,630	45,430	72,680
	Strength reduction factor for tension, steel failure mode	ϕ	-	0.75	0.75	0.75	0.75	0.75	0.75	0.75
	Strength reduction factor for shear, steel failure mode ¹	ϕ	-	0.65	0.65	0.65	0.65	0.65	0.65	0.65
	Reduction factor for seismic shear	$\alpha_{V,seis}$	-	0.70	0.70	0.70	0.70	0.70	0.70	0.70
Stainless Steel F593	F593 CW1 nominal steel strength in tension	N_{sa}	lb	7,365	13,480	21,470	-	-	-	-
	F593 CW1 nominal steel strength in shear	V_{sa}	lb	3,680	6,740	10,735	-	-	-	-
	F593 CW2 nominal steel strength in tension	N_{sa}	lb	-	-	-	25,385	35,110	46,055	73,645
	F593 CW2 nominal steel strength in shear	V_{sa}	lb	-	-	-	12,690	17,555	23,030	36,820
	Strength reduction factor for tension, steel failure mode ¹	ϕ	-	0.65	0.65	0.65	0.65	0.65	0.65	0.65
	Strength reduction factor for shear, steel failure mode	ϕ	-	0.60	0.60	0.60	0.60	0.60	0.60	0.60
	Reduction factor for seismic shear	$\alpha_{V,seis}$	-	0.70	0.70	0.70	0.70	0.70	0.70	0.70

For SI: 1 inch = 25.4mm, 1 lbf = 4.45N, 1ft-lbf = 1.356 N-M, 1 psi = 0.006895 MPa.

¹The tabulated value of ϕ applies when the load combinations of Section 1605.2 of the IBC, ACI 318-14 5.3 or ACI 318-11 9.2 are used. If the load combinations of ACI 318-11 Appendix C are used, the appropriate value of ϕ must be determined in accordance with ACI 318-11 D.4.4.

TABLE 2—CONCRETE BREAKOUT DESIGN INFORMATION FOR U.S. CUSTOMARY UNIT STEEL THREADED ROD ⁽¹⁾

CHARACTERISTIC	SYMBOL	UNITS	NOMINAL ROD DIAMETER (inch)						
			$\frac{3}{8}$	$\frac{1}{2}$	$\frac{5}{8}$	$\frac{3}{4}$	$\frac{7}{8}$	1	$1\frac{1}{4}$
Effectiveness factor for uncracked concrete	k_{uncr}	-	24	24	24	24	24	24	24
Effectiveness factor for cracked concrete	k_{cr}	-	17	17	17	17	17	17	17
Minimum concrete thickness	h_{min}	in.	$h_{ef} + 1\frac{1}{4}$		$h_{ef} + 2d_o$				
Anchor embedment depth - minimum	$h_{ef,min}$	in.	$1\frac{1}{2}$	2	$2\frac{1}{2}$	3	$3\frac{1}{2}$	4	5
Minimum spacing	s_{min}	in.	$\frac{15}{16}$	$1\frac{1}{2}$	$2\frac{1}{2}$	3	$3\frac{1}{2}$	4	5
Minimum edge distance	c_{min}	in.	$\frac{15}{16}$	$1\frac{1}{2}$	$2\frac{1}{2}$	3	$3\frac{1}{2}$	4	5
Critical edge distance	c_{ac}	in.	See Section 4.1.10 of this report						
Strength reduction factor for tension, concrete failure mode ¹	ϕ	Cond. B	0.65	0.65	0.65	0.65	0.65	0.65	0.65
Strength reduction factor for shear, concrete failure mode ¹	ϕ	Cond. B	0.70	0.70	0.70	0.70	0.70	0.70	0.70

For SI: 1 inch = 25.4mm, 1 lbf = 4.45N, 1ft-lbf = 1.356 N-M, 1 psi = 0.006895 MPa.

¹The tabulated value of ϕ applies when the load combinations of Section 1605.2 of the IBC, ACI 318-14 5.3 or ACI 318-11 9.2 are used and the requirements of ACI 318-14 17.3.3 or ACI 318-11 D.4.3, as applicable, for Condition B are met. If the load combinations of ACI 318-11 Appendix C are used, the appropriate value of ϕ must be determined in accordance with ACI 318-11 D.4.4 for Condition B.

TABLE 3—RED HEAD C6+ ADHESIVE ANCHOR BOND STRENGTH DESIGN INFORMATION FOR U.S. CUSTOMARY UNIT STEEL THREADED ROD INSTALLED IN HOLES DRILLED WITH A HAMMER DRILL AND CARBIDE BIT^(1,5)

CHARACTERISTIC		SYMBOL	UNITS	NOMINAL ROD DIAMETER (inch)						
				³ / ₈	¹ / ₂	⁵ / ₈	³ / ₄	⁷ / ₈	1	1 ¹ / ₄
Anchor embedment depth - minimum		h_{ef}	in.	1 ¹ / ₂	2	2 ¹ / ₂	3	3 ¹ / ₂	4	5
Anchor embedment depth - maximum		h_{ef}	in.	7 ¹ / ₂	10	12 ¹ / ₂	15	17 ¹ / ₂	20	25
Temperature Range A ²	Characteristic Bond Strength for Uncracked Concrete	$\mathcal{T}_{k,uncr}$	psi	2,470	2,390	2,315	2,240	2,160	2,085	1,930
	Characteristic Bond Strength for Cracked Concrete	$\mathcal{T}_{k,cr}$	psi	1,125	1,125	1,125	1,255	1,255	1,255	1,370
Temperature Range B ^{3,4}	Characteristic Bond Strength for Uncracked Concrete	$\mathcal{T}_{k,uncr}$	psi	2,110	2,040	1,975	1,910	1,845	1,780	1,645
	Characteristic Bond Strength for Cracked Concrete	$\mathcal{T}_{k,cr}$	psi	960	960	960	1,070	1,070	1,070	1,170
Continuous Inspection	Strength Reduction Factor - Dry Concrete	$\phi_{dry, ci}$	-	0.65	0.65	0.65	0.65	0.65	0.65	0.65
	Strength Reduction Factor - Water-Saturated Concrete	$\phi_{sat, ci}$	-	0.65	0.65	0.65	0.65	0.65	0.65	0.65
	Strength Reduction Factor - Water-Filled Holes	$\phi_{wf, ci}$	-	0.65	0.65	0.65	0.65	0.65	0.65	0.65
	Strength Reduction Factor - Submerged Concrete	$\phi_{sub, ci}$	-	0.65	0.65	0.55	0.55	0.55	0.55	0.55
Periodic Inspection	Strength Reduction Factor - Dry Concrete	$\phi_{dry, pi}$	-	0.65	0.65	0.65	0.55	0.55	0.55	0.55
	Strength Reduction Factor - Water-Saturated Concrete	$\phi_{sat, pi}$	-	0.65	0.65	0.65	0.55	0.55	0.55	0.65
	Strength Reduction Factor - Water-Filled Holes	$\phi_{wf, pi}$	-	0.55	0.55	0.55	0.55	0.55	0.55	0.55
	Strength Reduction Factor - Submerged Concrete	$\phi_{sub, pi}$	-	0.55	0.65	0.55	0.45	0.45	0.45	0.45
Submerged Installation Reduction Factor		$\alpha_{N,sub}$	-	1.00	1.00	1.00	1.00	1.00	0.81	1.00
Reduction factor for seismic tension		$\alpha_{N,seis}$	-	0.95	0.98	0.96	0.96	0.94	0.94	0.94

For SI: 1 inch = 25.4mm, 1 lbf = 4.45N, 1ft-lbf = 1.356 N-M, 1 psi = 0.006895 MPa.

¹Bond strength values correspond to concrete compressive strengths ranging from 2,500 psi to 8,000.

²Temperature range A: Maximum short term temperature of 142°F and maximum long term temperature of 110°F.

³Temperature range B: Maximum short term temperature of 165°F and maximum long term temperature of 110°F.

⁴For load combinations consisting of only short-term loads, such as wind or seismic loads, bond strengths may be increased by 4 percent for Temperature Range B.

⁵For structures assigned to IBC or IRC Seismic Design Category C, D, E, or F, bond strength values must be multiplied by $\alpha_{N,seis}$.

TABLE 4—RED HEAD C6+ ADHESIVE ANCHOR BOND STRENGTH DESIGN INFORMATION FOR U.S. CUSTOMARY UNIT STEEL THREADED ROD INSTALLED IN HOLES CORE DRILLED WITH A DIAMOND CORE BIT^(1,5)

CHARACTERISTIC	SYMBOL	UNITS	NOMINAL ROD DIAMETER (inch)							
			³ / ₈	¹ / ₂	⁵ / ₈	³ / ₄	⁷ / ₈	1	1 ¹ / ₄	
Anchor embedment depth - minimum	h_{ef}	in.	1 ¹ / ₂	2	2 ¹ / ₂	3	3 ¹ / ₂	4	5	
Anchor embedment depth - maximum	h_{ef}	in.	7 ¹ / ₂	10	12 ¹ / ₂	15	17 ¹ / ₂	20	25	
Temperature Range A ²	Characteristic Bond Strength for Uncracked Concrete	$\mathcal{T}_{k,uncr}$	psi	1,935	1,750	1,590	1,460	1,360	1,285	1,225
	Characteristic Bond Strength for Cracked Concrete	$\mathcal{T}_{k,cr}$	psi	1,010	1,010	1,010	1,030	975	965	1,030
Temperature Range B ^{3,4}	Characteristic Bond Strength for Uncracked Concrete	$\mathcal{T}_{k,uncr}$	psi	1,650	1,490	1,355	1,245	1,160	1,100	1,045
	Characteristic Bond Strength for Cracked Concrete	$\mathcal{T}_{k,cr}$	psi	860	860	860	880	835	825	880
Continuous Inspection	Strength Reduction Factor - Dry Concrete	$\phi_{dry, ci}$	-	0.65	0.65	0.65	0.65	0.65	0.65	0.65
	Strength Reduction Factor - Water-Saturated Concrete	$\phi_{sat, ci}$	-	0.65	0.65	0.65	0.65	0.65	0.65	0.65
	Strength Reduction Factor - Water-Filled Holes	$\phi_{wf, ci}$	-	0.65	0.65	0.65	0.65	0.65	0.65	0.65
	Strength Reduction Factor - Submerged Concrete	$\phi_{sub, ci}$	-	0.65	0.65	0.65	0.65	0.65	0.65	0.65
Periodic Inspection	Strength Reduction Factor - Dry Concrete	$\phi_{dry, pi}$	-	0.65	0.65	0.65	0.55	0.55	0.55	0.65
	Strength Reduction Factor - Water-Saturated Concrete	$\phi_{sat, pi}$	-	0.65	0.65	0.65	0.65	0.65	0.65	0.65
	Strength Reduction Factor - Water-Filled Holes	$\phi_{wf, pi}$	-	0.65	0.65	0.65	0.55	0.55	0.55	0.65
	Strength Reduction Factor - Submerged Concrete	$\phi_{sub, pi}$	-	0.65	0.65	0.65	0.55	0.65	0.65	0.65
Submerged Installation Reduction Factor	$\alpha_{N,sub}$	-	1.00	1.00	1.00	1.00	1.00	1.00	1.00	
Reduction factor for seismic tension	$\alpha_{N,seis}$	-	0.95	0.98	0.96	0.96	0.94	0.94	0.94	

For SI: 1 inch = 25.4mm, 1 lbf = 4.45N, 1ft-lbf = 1.356 N-M, 1 psi = 0.006895 MPa.

¹Bond strength values correspond to concrete compressive strengths ranging from 2,500 psi to 8,000 psi.

²Temperature range A: Maximum short term temperature of 142°F and maximum long term temperature of 110°F.

³Temperature range B: Maximum short term temperature of 165°F and maximum long term temperature of 110°F.

⁴For load combinations consisting of only short-term loads, such as wind or seismic loads, bond strengths may be increased by 4 percent for Temperature Range B.

⁵For structures assigned to IBC or IRC Seismic Design Category C, D, E, or F, bond strength values must be multiplied by $\alpha_{N,seis}$.

TABLE 5—STEEL DESIGN INFORMATION FOR U.S. CUSTOMARY UNIT STEEL REINFORCING BARS ⁽¹⁾

CHARACTERISTIC	SYMBOL	UNITS	NOMINAL ROD DIAMETER (inch)								
			No. 3	No. 4	No. 5	No. 6	No. 7	No. 8	No. 9	No. 10	
Nominal bar diameter	<i>d</i>	in.	3/8	1/2	5/8	3/4	7/8	1	1 1/8	1 1/4	
Reinforcing bar effective cross-sectional area	<i>A_{se}</i>	inch ²	0.11	0.2	0.31	0.44	0.6	0.79	1.00	1.27	
ASTM 615 Grade 60	Nominal steel strength in tension	<i>N_{sa}</i>	lb	9,900	18,000	27,900	39,600	54,000	71,100	90,000	114,300
	Nominal steel strength in shear	<i>V_{sa}</i>	lb	5,940	10,800	16,740	23,760	32,400	42,660	54,000	68,580
	Strength reduction factor for tension, steel failure mode	<i>φ</i>	-	0.65	0.65	0.65	0.65	0.65	0.65	0.65	0.65
	Strength reduction factor for shear, steel failure mode ¹	<i>φ</i>	-	0.60	0.60	0.60	0.60	0.60	0.60	0.60	0.60
	Reduction factor for seismic shear	<i>α_{V,seis}</i>	-	0.91	0.91	0.91	0.90	0.90	0.71	0.71	0.71

For SI: 1 inch = 25.4mm, 1 lbf = 4.45N, 1ft-lbf = 1.356 N-M, 1 psi = 0.006895 MPa.

¹The tabulated value of *φ* applies when the load combinations of Section 1605.2 of the IBC, ACI 318-14 5.3 or ACI 318-11 9.2 are used. If the load combinations of ACI 318-11 Appendix C are used, the appropriate value of *φ* must be determined in accordance with ACI 318-11 D.4.4.

TABLE 6—CONCRETE BREAKOUT DESIGN INFORMATION FOR U.S. CUSTOMARY UNIT STEEL REINFORCING BARS ^(1,2)

CHARACTERISTIC	SYMBOL	UNITS	NOMINAL ROD DIAMETER (inch)							
			No. 3	No. 4	No. 5	No. 6	No. 7	No. 8	No. 9	No. 10
Effectiveness factor for uncracked concrete	<i>k_{uncr}</i>	-	24	24	24	24	24	24	24	24
Effectiveness factor for cracked concrete	<i>k_{cr}</i>	-	17	17	17	17	17	17	17	17
Minimum concrete thickness	<i>h_{min}</i>	in.	<i>h_{ef}</i> + 1 1/4			<i>h_{ef}</i> + 2 <i>d_o</i>				
Anchor embedment depth - minimum	<i>h_{ef,min}</i>	in.	1 1/2	2	2 1/2	3	3 1/2	4	4 1/2	5
Minimum spacing	<i>s_{min}</i>	in.	15/16	1 1/2	2 1/2	3	3 1/2	4	4 1/2	5
Minimum edge distance	<i>c_{min}</i>	in.	15/16	1 1/2	2 1/2	3	3 1/2	4	4 1/2	5
Critical edge distance	<i>c_{ac}</i>	in.	See Section 4.1.10 of this report							
Strength reduction factor for tension, concrete failure mode ¹	<i>φ</i>	Cond. B	0.65	0.65	0.65	0.65	0.65	0.65	0.65	0.65
Strength reduction factor for shear, concrete failure mode ¹	<i>φ</i>	Cond. B	0.70	0.70	0.70	0.70	0.70	0.70	0.70	0.70

For SI: 1 inch = 25.4mm, 1 lbf = 4.45N, 1ft-lbf = 1.356 N-M, 1 psi = 0.006895 MPa.

¹The tabulated value of *φ* applies when the load combinations of Section 1605.2 of the IBC, ACI 318-14 5.3 or ACI 318-11 9.2 are used and the requirements of ACI 318-14 17.3.3 or ACI 318-11 D.4.3, as applicable, for Condition B are met. If the load combinations of ACI 318-11 Appendix C are used, the appropriate value of *φ* must be determined in accordance with ACI 318-11 D.4.4 for Condition B.

²The value of *f_c* used for calculation must be limited to maximum 8,000 psi (55 MPa) in accordance with ACI 318-14 17.2.7 or ACI 318-11 D.3.7, as applicable.

TABLE 7—RED HEAD C6+ ADHESIVE ANCHOR BOND STRENGTH DESIGN INFORMATION FOR U.S. CUSTOMARY UNIT STEEL REINFORCING BARS INSTALLED IN HOLES PREPARED WITH A HAMMER DRILL AND CARBIDE BIT^(1,5)

CHARACTERISTIC	SYMBOL	UNITS	NOMINAL ROD DIAMETER (inch)								
			No. 3	No. 4	No. 5	No. 6	No. 7	No. 8	No. 9	No. 10	
Anchor embedment depth - minimum	h_{ef}	in.	1½	2	2½	3	3½	4	4½	5	
Anchor embedment depth - maximum	h_{ef}	in.	7½	10	12½	15	17½	20	22½	25	
Temperature Range A ²	Characteristic Bond Strength for Uncracked Concrete	$f_{k,uncr}$	psi	2,365	2,275	2,180	2,085	1,990	1,895	1,805	1,710
	Characteristic Bond Strength for Cracked Concrete	$f_{k,cr}$	psi	1,125	1,125	1,110	1,190	1,140	1,090	1,040	1,080
Temperature Range B ^{3,4}	Characteristic Bond Strength for Uncracked Concrete	$f_{k,uncr}$	psi	2,020	1,940	1,860	1,780	1,700	1,620	1,540	1,460
	Characteristic Bond Strength for Cracked Concrete	$f_{k,cr}$	psi	960	960	945	1,015	975	930	890	925
Continuous Inspection	Strength Reduction Factor - Dry Concrete	$\phi_{dry, ci}$	-	0.65	0.65	0.65	0.65	0.65	0.65	0.65	0.65
	Strength Reduction Factor - Water-Saturated Concrete	$\phi_{sat, ci}$	-	0.65	0.65	0.65	0.65	0.65	0.65	0.65	0.65
	Strength Reduction Factor - Water-Filled Holes	$\phi_{wf, ci}$	-	0.65	0.65	0.65	0.65	0.65	0.65	0.65	0.65
	Strength Reduction Factor - Submerged Concrete	$\phi_{sub, aci}$	-	0.65	0.65	0.65	0.55	0.55	0.55	0.55	0.55
Periodic Inspection	Strength Reduction Factor - Dry Concrete	$\phi_{dry, pi}$	-	0.65	0.65	0.65	0.55	0.55	0.55	0.55	0.55
	Strength Reduction Factor - Water-Saturated Concrete	$\phi_{sat, pi}$	-	0.65	0.65	0.65	0.55	0.55	0.55	0.55	0.65
	Strength Reduction Factor - Water-Filled Holes	$\phi_{wf, pi}$	-	0.55	0.55	0.55	0.55	0.55	0.55	0.55	0.55
	Strength Reduction Factor - Submerged Concrete	$\phi_{sub, pi}$	-	0.55	0.65	0.55	0.45	0.45	0.45	0.45	0.45
Submerged Installation Reduction Factor	$\alpha_{N,sub}$	-	1.00	1.00	1.00	1.00	1.00	0.81	0.81	1.00	
Reduction factor for seismic tension	$\alpha_{N,seis}$	-	0.88	0.88	0.88	0.84	0.84	0.84	0.84	0.95	

For **SI**: 1 inch = 25.4mm, 1 lbf = 4.45N, 1ft-lbf = 1.356 N-M, 1 psi = 0.006895 MPa.

¹Bond strength values correspond to concrete compressive strengths ranging from 2,500 psi to 8,000.

²Temperature range A: Maximum short term temperature of 142°F and maximum long term temperature of 110°F.

³Temperature range B: Maximum short term temperature of 165°F and maximum long term temperature of 110°F.

⁴For load combinations consisting of only short-term loads, such as wind or seismic loads, bond strengths may be increased by 4 percent for Temperature Range B.

⁵For structures assigned to IBC or IRC Seismic Design Category C, D, E, or F, bond strength values must be multiplied by $\alpha_{N,seis}$.

TABLE 8—RED HEAD C6+ ADHESIVE ANCHOR BOND STRENGTH DESIGN INFORMATION FOR U.S. CUSTOMARY UNIT STEEL REINFORCING BARS INSTALLED IN HOLES CORE DRILLED WITH A DIAMOND CORE BIT ^(1,5)

CHARACTERISTIC	SYMBOL	UNITS	NOMINAL ROD DIAMETER (inch)								
			No. 3	No. 4	No. 5	No. 6	No. 7	No. 8	No. 9	No. 10	
Anchor embedment depth - minimum	h_{ef}	in.	1½	2	2½	3	3½	4	4½	5	
Anchor embedment depth - maximum	h_{ef}	in.	7½	10	12½	15	17½	20	22½	25	
Temperature Range A ²	Characteristic Bond Strength for Uncracked Concrete	$f_{k,uncr}$	psi	1,855	1,660	1,495	1,360	1,255	1,170	1,145	1,085
	Characteristic Bond Strength for Cracked Concrete	$f_{k,cr}$	psi	1,010	1,010	995	975	885	840	800	815
Temperature Range B ^{3,4}	Characteristic Bond Strength for Uncracked Concrete	$f_{k,uncr}$	psi	1,585	1,420	1,280	1,160	1,070	1,000	980	930
	Characteristic Bond Strength for Cracked Concrete	$f_{k,cr}$	psi	860	860	850	835	755	715	685	695
Continuous Inspection	Strength Reduction Factor - Dry Concrete	$\phi_{dry, ci}$	-	0.65	0.65	0.65	0.65	0.65	0.65	0.65	0.65
	Strength Reduction Factor - Water-Saturated Concrete	$\phi_{sat, ci}$	-	0.65	0.65	0.65	0.65	0.65	0.65	0.65	0.65
	Strength Reduction Factor - Water-Filled Holes	$\phi_{wf, ci}$	-	0.65	0.65	0.65	0.65	0.65	0.65	0.65	0.65
	Strength Reduction Factor - Submerged Concrete	$\phi_{sub, aci}$	-	0.65	0.65	0.65	0.65	0.65	0.65	0.65	0.65
Periodic Inspection	Strength Reduction Factor - Dry Concrete	$\phi_{dry, pi}$	-	0.65	0.65	0.65	0.55	0.55	0.55	0.55	0.65
	Strength Reduction Factor - Water-Saturated Concrete	$\phi_{sat, pi}$	-	0.65	0.65	0.65	0.65	0.65	0.65	0.65	0.65
	Strength Reduction Factor - Water-Filled Holes	$\phi_{wf, pi}$	-	0.65	0.65	0.65	0.55	0.55	0.55	0.55	0.65
	Strength Reduction Factor - Submerged Concrete	$\phi_{sub, pi}$	-	0.65	0.65	0.65	0.55	0.65	0.65	0.65	0.65
Submerged Installation Reduction Factor	$\alpha_{N,sub}$	-	1.00	1.00	1.00	1.00	1.00	1.00	1.00	1.00	
Reduction factor for seismic tension	$\alpha_{N,seis}$	-	0.88	0.88	0.88	0.84	0.84	0.84	0.84	0.95	

For SI: 1 inch = 25.4mm, 1 lbf = 4.45N, 1ft-lbf = 1.356 N-M, 1 psi = 0.006895 MPa.

¹Bond strength values correspond to concrete compressive strengths ranging from 2,500 psi to 8,000 psi.

²Temperature range A: Maximum short term temperature of 142°F and maximum long term temperature of 110°F.

³Temperature range B: Maximum short term temperature of 165°F and maximum long term temperature of 110°F.

⁴For load combinations consisting of only short-term loads, such as wind or seismic loads, bond strengths may be increased by 4 percent for Temperature Range B.

⁵For structures assigned to IBC or IRC Seismic Design Category C, D, E, or F, bond strength values must be multiplied by $\alpha_{N,seis}$.

TABLE 9—EXAMPLE RED HEAD C6+ ADHESIVE ANCHOR ALLOWABLE STRESS DESIGN VALUES (ASD) FOR ILLUSTRATIVE PURPOSES

Anchor Diameter (d)	Min/Max Embedment Depth, h _{ef} (in)	Char. Bond Strength τ _{k,uncr} (psi)	Allowable Tension Load (lb) 2500psi- 8000psi	Controlling Failure Mode
3/8	2 3/8	2,470	1,929	Concrete
	7 1/2		4,910	Steel
1/2	2 3/4	2,390	2,403	Concrete
	10		8,990	Steel
5/8	3 1/8	2,315	2,911	Concrete
	12 1/2		14,315	Steel
3/4	3 1/2	2,240	3,451	Concrete
	15		21,185	Steel
7/8	3 1/2	2,160	3,451	Concrete
	17 1/2		29,245	Steel
1	4	2,085	4,216	Concrete
	20		38,365	Steel
1 1/4	5	1,930	5,892	Concrete
	25		61,390	Steel

For **SI**: 1 inch = 25.4mm, 1 lbf = 4.45N, 1ft-lbf = 1.356 N-M, 1 psi = 0.006895 MPa.

This table was developed based on the following conditions:

- ¹Single anchor with static tension only, A193 Grade B7 threaded rod
- ²Vertical downward installation direction
- ³Inspection regimen = Periodic
- ⁴Installation temperature = 50°F to 110°F
- ⁵Long term temperature = 110°F
- ⁶Short term temperature = 142°F
- ⁷Dry hole condition (carbide drilled hole)
- ⁸Embedment = h_{ef} (min/max for each diameter)
- ⁹Concrete determined to remain uncracked for the life of the anchorage
- ¹⁰Load combinations from ACI 318-11 Section 9.2 (no seismic loading)
- ¹¹30% dead load and 70% live load, controlling load combination 1.2D + 1.6L
- ¹²Calculation of weighted average for α = 0.3*1.2 + 0.7*1.6 = 1.48
- ¹³f_c = 2,500 psi (normalweight concrete)
- ¹⁴c_{a1} = c_{a2} ≥ c_{ac}
- ¹⁵h ≥ h_{min}

Illustrative Procedure to Calculate Allowable Stress Design Tension Value:

Red Head C6+ Adhesive Anchor 1/2-inch diameter, using an embedment of 4 1/2 inches, assuming the conditions given in Table 9 (for use with the 2012 IBC, based on ACI 318-11 Appendix D). Applied tension load, N_{ua} = 4,000 lbs.

	PROCEDURE	CALCULATION
Step 1	Calculate steel strength of a single anchor in tension per ACI 318-11 D.5.1.2 and Table 1 of this report.	φ N _{sa} = 0.75*17,740 = 13,305 lbs steel strength
Step 2	Calculate concrete breakout strength of a single anchor in tension per ACI 318-11 D.5.2 and Table 2 of this report.	N _b = k _{c,uncr} *λ _a √f _c h _{ef} ^{1.5} = 24*√2,500*4.5 ^{1.5} N _b = 11,455 lbs φ N _{cb} = φ A _{NC} /A _{NC0} ψ _{ed,N} ψ _{c,N} ψ _{cp,N} N _b φ N _{cb} = 0.65*1.0*1.0*1.0*11,455 φ N _{cb} = 7,446 lbs concrete breakout strength
Step 3	Calculate bond strength of a single anchor in tension per ACI 318-11 D.5.5 and Table 3 of this report.	N _{ba} = *λ _a τ _{k,uncr} π d h _{ef} N _{ba} = 1.0*2,390*3.14*0.5*4.5 N _{ba} = 16,885 lbs φ N _a = φ A _{Na} /A _{Na0} ψ _{ed,Na} ψ _{cp,Na} N _{a0} φ N _a = 0.65*1.0*1.0*1.0*16,885 φ N _a = 10,975 lbs bond strength
Step 4	Determine compliance with required anchor strength per ACI 318-11 D.4.1.	φ N _{sa} = 13,305 lbs > N _{ua} = 4,000 lbs φ N _{cb} = 7,446 lbs > N _{ua} = 4,000 lbs φ N _a = 10,975 lbs > N _{ua} = 4,000 lbs
Step 5	Calculate allowable stress design conversion factor for loading condition per ACI 318-11 Section 9.2.	α = 1.2D + 1.6L = 1.2(0.3) + 1.6(0.7) = 1.48
Step 6	Calculate allowable stress design value per Section 4.2 of this report.	T _{allowable,ASD} = φ N _n / α = 7,446 lbs/1.48 T _{allowable,ASD} = 3,270 lbs allowable stress design

FIGURE 2—EXAMPLE DESIGN CALCULATION

RED HEAD C6+ ADHESIVE ANCHOR INSTALLATION INSTRUCTION

Hammer Drilling Installation

* Water-saturated concrete, water-filled holes and submerged concrete applications require 4x's air, 4x's brushing and 4x's air

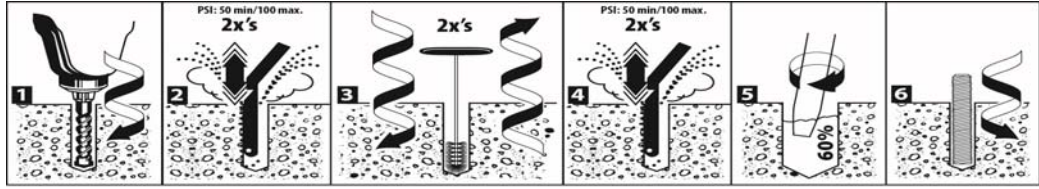

- 1)
 - Use a rotary hammer drill with a carbide drill bit complying to ANSI B212.15-1994 tolerance requirements or a core drill with diamond core bit. Drill hole to the required embedment depth. See attached table for drill bit specifications and min/maximum embedment depths.
 - Installations may be used with maximum 1-1/4" diameter rods/rebar for floor, wall and overhead applications.
 - Per construction specification, adhere to minimum spacing, minimum edge distance, and minimum member thickness.
 - 2)
 - For dry holes, oscillate a clean air nozzle in and out of the dry hole two times, for a total of two seconds, starting at the bottom of the hole with contaminant-free compressed air, exhausting hole until visually clean (i.e., no dust, debris, etc.)
 - For water-saturated concrete and water-filled hole applications, oscillate a clean air nozzle in and out of the damp, water-filled or submerged hole four times, for a total of four seconds, starting at the bottom of the hole with contaminant-free compressed air, exhausting hole until visually clean (i.e., no dust, debris, etc.)
 - If required, use an extension on the end of the air nozzle to reach the bottom of the hole.
 - For core drilled holes, flush the hole twice with water, starting from the back of the hole using water line pressure.
 - 3)
 - Select an appropriately sized Red Head brush for the anchor diameter. Brush must be checked for wear before use. See attached table for brush specifications, including minimum diameter.
 - Insert the brush into the hole with a clockwise motion. For every 1/2" forward advancement, complete one full turn until bottom of hole is reached. For faster and more suitable cleaning, attach the brush to a drill.
 - Using a clockwise motion, for every full turn of the brush, pull the brush 1/2" out of the hole.
 - For dry holes, twist/spin the brush two times in/out of the hole.
 - For water-saturated concrete and water-filled hole applications, twist/spin the brush four times in/out of the hole.
 - If required, use a wire brush extension (part nos. ESDS-38 or EHAN-38) to reach the bottom of the hole.
 - Air clean the dust off the brush to prevent clogging of the brush.
 - For core drilled holes, twist/spin the brush two times in/out of the hole.
 - 4)
 - For dry holes, oscillate a clean air nozzle in and out of the dry hole two times, for a total of two seconds, starting at the bottom of the hole with contaminant-free compressed air, exhausting hole until visually clean (i.e., no dust, debris, etc.)
 - For water-saturated concrete and water-filled hole applications, oscillate a clean air nozzle in and out of the damp, water-filled or submerged hole four times, for a total of four seconds, starting at the bottom of the hole with contaminant-free compressed air, exhausting hole until visually clean (i.e., no dust, debris, etc.)
 - For core drilled holes, flush the hole twice with water, starting from the back of the hole using water line pressure. Remove any remaining water in the hole using compressed air.
 - 5)
 - Review the Safety Data Sheet (SDS) before use.
 - Check the "Use By" date on the cartridge and that the cartridge has been stored out of direct sunlight.
 - Review the gel time/cure time chart, based on the temperature at time of installation, to determine tool, cartridge and nozzle requirements.
-
- Assemble the Red Head supplied cartridge and nozzle. Do not modify or remove mixing elements in nozzle.
 - If nozzle does not reach the bottom of the hole, use Red Head E25-6 extension tubing (0.44" O.D.) positioned on the end of nozzle or use the S75EXT (nozzle extension) on the end of the S75 nozzle.
 - Place the assembly into a hand injection tool or a pneumatic injection tool.
 - Dispense mixed adhesive outside of hole until uniform color is achieved.
 - During installations, concrete must be between 50 and 110 degrees F, or artificially maintained.
 - Insert the nozzle to the bottom of the hole and inject the adhesive at an angle, leaving the nozzle tip always slightly below the fill level.
 - In a slow circular direction, work the adhesive into the sides of the hole, filling slowly to ensure proper adhesive distribution, until the hole is approximately 60% filled.
 - For holes that contain water, keep injecting the adhesive below the water to displace the water upward.
- HORIZONTAL AND OVERHEAD INJECTION OF ADHESIVE:**
- For 3/8" and 1/2" diameter anchors installed horizontal and overhead, the adhesive may be injected directly to the back end of the hole using required Red Head E916-6 extension tubing (0.56" O.D.) for the 1/2" diameter anchors and Red Head E25-6 extension tubing (0.44" O.D.) for the 3/8" diameter anchors.
 - For 5/8" diameter rod (#5 rebar) and larger anchors installed horizontal and overhead, assemble Red Head E916-6 extension tubing (0.56" O.D.) and appropriate sized piston plug on end of tubing:
 - PL-5834 for 5/8" & 3/4" diameter rod (No. 5 and No. 6 rebar)
 - PL-7810 for 7/8" & 1" diameter rod (No. 7 and No. 8 rebar)
 - PL-1250 for 1-1/4" diameter rod (No. 9 and No. 10 rebar)
 - The use of the Red Head pneumatic tool may be required for larger diameter anchor and/or deeper embedment installations at temperatures up to 110 degrees F.
- 6)
 - Immediately insert the oil, rust and scale free rod/rebar assembly to the required embedment depth, using a counterclockwise motion to ensure proper adhesive distribution.
 - The anchor rod/rebar must be marked with the required embedment depth.
 - For wall (horizontal) and overhead installations with concrete or adhesive over 70 degrees F, the anchor rod/rebar must be marked with the required embedment depth and assembled with a Red Head hole plug positioned on the rod/rebar at the required embedment depth.
 - After installing the anchor, the gap between the rod and the concrete must be completely filled with adhesive. The adhesive must fill voids, crevices and uniformly coat the rod and concrete.
 - After installation, do not disturb the anchor until the full cure time has elapsed. Overhead installations must be supported until full cure time has elapsed.
 - Adhesive must be fully cured before applying any load or torque. Do not over torque the anchor as this could adversely affect its performance.

Core Drilling Installation

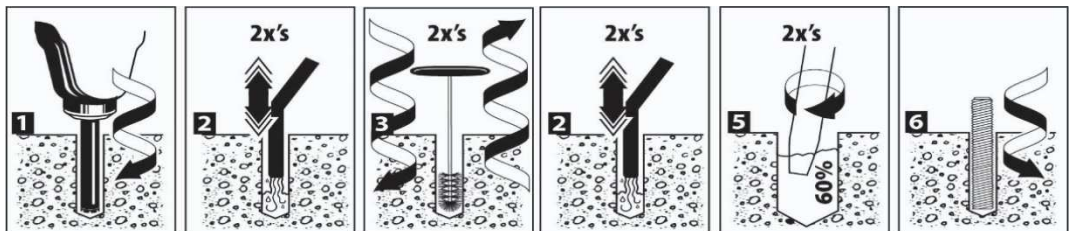

FIGURE 3—RED HEAD C6+ ADHESIVE INSTALLATION INSTRUCTIONS

SPECIFICATIONS FOR INSTALLATION OF RED HEAD C6+ ADHESIVE ANCHORS IN CONCRETE

FOR INSTALLATION USING U.S. CUSTOMARY UNIT STEEL THREADED ROD

CHARACTERISTIC	SYMBOL	UNITS	NOMINAL ROD DIAMETER (inch)						
			3/8	1/2	5/8	3/4	7/8	1	1 1/4
Nominal carbide bit/diamond core bit diameter	-	in.	7/16	9/16	3/4	7/8	1	1 1/8	1 3/8
Anchor embedment depth - minimum	$h_{ef, min}$	in.	2 3/8	2 3/4	3 1/8	3 1/2	3 1/2	4	5
Anchor embedment depth - maximum	$h_{ef, max}$	in.	7 1/2	10	12 1/2	15	17 1/2	20	25
Minimum spacing	s_{min}	in.	15/16	1 1/2	2 1/2	3	3 1/2	4	5
Minimum edge distance	c_{min}	in.	15/16	1 1/2	2 1/2	3	3 1/2	4	5
Minimum concrete thickness	h_{min}	in.	$h_{ef} + 1 1/4$			$h_{ef} + 2d_o$			
Maximum tightening torque for pretension clamping	T_{inst}	ft lb	9	16	47	70	90	110	370

FOR INSTALLATION USING U.S. CUSTOMARY UNIT STEEL REINFORCING BARS

CHARACTERISTIC	SYMBOL	UNITS	NOMINAL REBAR DIAMETER (inch)							
			No. 3	No. 4	No. 5	No. 6	No. 7	No. 8	No. 9	No. 10
Nominal carbide bit/diamond core bit diameter	-	in.	7/16	5/8	3/4	7/8	1	1 1/8	1 1/4	1 3/8
Anchor embedment depth - minimum	$h_{ef, min}$	in.	2 3/8	2 3/4	3 1/8	3 1/2	3 1/2	4	4 1/2	5
Anchor embedment depth - maximum	$h_{ef, max}$	in.	7 1/2	10	12 1/2	15	17 1/2	20	22 1/2	25
Minimum spacing	s_{min}	in.	15/16	1 1/2	2 1/2	3	3 1/2	4	4 1/2	5
Minimum edge distance	c_{min}	in.	15/16	1 1/2	2 1/2	3	3 1/2	4	4 1/2	5
Minimum concrete thickness	h_{min}	in.	$h_{ef} + 1 1/4$			$h_{ef} + 2d_o$				

For SI: 1 inch = 25.4mm, 1 lbf = 4.45N, 1ft-lbf = 1.356N-m, 1psi = 0.006895MPa.

ANCHOR INSTALLATION

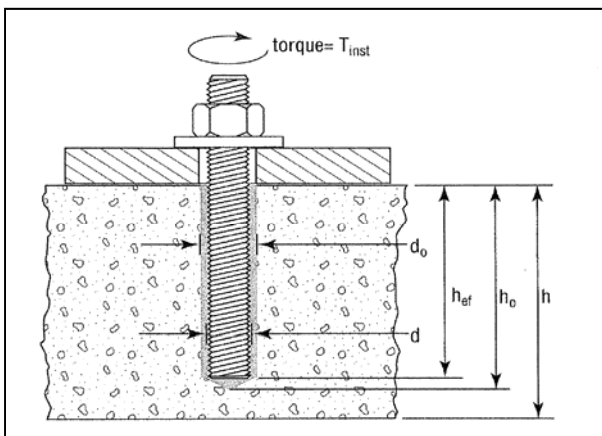

BRUSH, NOZZLE, EXTENSION TUBING AND PISTON PLUG SPECIFICATIONS

Anchor diameter (in) (d)	Brush Part No.	Minimum brush diameter (in)	Mixing nozzle	USE of extension tubing ONLY Part No	USE of Piston Plug with extension tubing Part Nos.
3/8	WB038	0.563	A24S or S55	E25-6	-
1/2	WB012	0.675	A24S or S55	E25-6	-
5/8	WB058	0.900	A24S or S55	-	PL-5834 E916-6
3/4	WB034	1.125	S55 or S75/S75EXT	-	PL-5834 E916-6
7/8	WB078	1.350	S55 or S75/S75EXT	-	PL-7810 E916-6
1 & 1/8	WB100	1.463	S55 or S75/S75EXT	-	PL-7810 E916-6
1 1/4	WB125	1.575	S55 or S75/S75EXT	-	PL-1250 E916-6

FIGURE 3—RED HEAD C6+ ADHESIVE INSTALLATION INSTRUCTIONS (Continued)

CURE TIMES AND GEL TIMES FOR RED HEAD C6+ ADHESIVE

Concrete Temperature (°F) ¹	Gel Time ²	Cure Time ³
110	10 minutes	2 hours
90	14 minutes	2.75 hours
70	16 minutes	6.5 hours
50	30 minutes	24 hours

For SI: $t^{\circ} (\text{°F}-32) \times .555 = \text{°C}$.

¹Adhesive must be installed in concrete temperatures within the noted range or artificially maintained at the noted temperature.

²Gel time is the maximum time from the end of mixing to when the insertion of the anchor into the adhesive must be completed and is based upon the adhesive and concrete temperatures noted.

³Cure time is the minimum time from the end of gel time to when the anchor maybe torque or loaded. Anchors are to be undisturbed during the cure time.

FIGURE 3—RED HEAD C6+ ADHESIVE INSTALLATION INSTRUCTIONS (Continued)

DIVISION: 03 00 00—CONCRETE**Section: 03 16 00—Concrete Anchors****DIVISION: 05 00 00—METALS****Section: 05 05 19—Post-Installed Concrete Anchors****REPORT HOLDER:**

ITW RED HEAD

EVALUATION SUBJECT:

ITW RED HEAD C6+ ADHESIVE ANCHORING SYSTEM FOR CRACKED AND UNCRACKED CONCRETE

1.0 REPORT PURPOSE AND SCOPE**Purpose:**

The purpose of this evaluation report supplement is to indicate that the ITW Red Head C6+ Adhesive Anchoring System for cracked and uncracked concrete, described in ICC-ES evaluation report [ESR-4046](#), has also been evaluated for compliance with the codes noted below as adopted by the Los Angeles Department of Building and Safety (LADBS).

Applicable code editions:

- 2017 *City of Los Angeles Building Code* (LABC)
- 2017 *City of Los Angeles Residential Code* (LARC)

2.0 CONCLUSIONS

The ITW Red Head C6+ Adhesive Anchoring System for cracked and uncracked concrete, described in Sections 2.0 through 7.0 of the evaluation report [ESR-4046](#), complies with LABC Chapter 19, and LARC, and is subjected to the conditions of use described in this supplement.

3.0 CONDITIONS OF USE

The ITW Red Head C6+ Adhesive Anchoring System described in this evaluation report must comply with all of the following conditions:

- All applicable sections in the evaluation report [ESR-4046](#).
- The design, installation, conditions of use and identification of the anchoring system are in accordance with the 2015 *International Building Code*® (2015 IBC) provisions noted in the evaluation report [ESR-4046](#).
- The design, installation and inspection are in accordance with additional requirements of LABC Chapters 16 and 17, as applicable.
- Under the LARC, an engineered design in accordance with LARC Section R301.1.3 must be submitted.
- The allowable and strength design values listed in the evaluation report and tables are for the connection of the adhesive anchors to the concrete. The connection between the adhesive anchors and the connected members shall be checked for capacity (which may govern).

This supplement expires concurrently with the evaluation report, reissued September 2021.

DIVISION: 03 00 00—CONCRETE

Section: 03 16 00—Concrete Anchors

DIVISION: 05 00 00—METALS

Section: 05 05 19—Post-Installed Concrete Anchors

ITW RED HEAD

EVALUATION SUBJECT:

ITW RED HEAD C6+ ADHESIVE ANCHORING SYSTEM FOR CRACKED AND UNCRACKED CONCRETE

1.0 REPORT PURPOSE AND SCOPE

Purpose:

The purpose of this evaluation report supplement is to indicate that Red Head C6+ Adhesive Anchoring System for Cracked and Uncracked Concrete, described in ICC-ES evaluation report ESR-4046, has also been evaluated for compliance with the codes noted below.

Compliance with the following codes:

- 2014 *Florida Building Code—Building*
- 2014 *Florida Building Code—Residential*

2.0 PURPOSE OF THIS SUPPLEMENT

This supplement is issued to indicate that the Red Head C6+ Adhesive Anchoring System for Cracked and Uncracked Concrete described in Sections 2.0 through 7.0 of the evaluation report, ESR-4046, complies with the *Florida Building Code—Building* and the *Florida Building Code—Residential*, when designed and installed in accordance with the 2012 *International Building Code*® (IBC) provisions noted in the evaluation report under the following conditions:

- Design wind loads must be based on Section 1609 of the *Florida Building Code—Building* or Section 301.2.1.1 of the *Florida Building Code—Residential*, as applicable.
- Load combinations must be in accordance with Section 1605.2 or Section 1605.3 of the 2014 *Florida Building Code—Building*, as applicable.

Use of the Red Head C6+ Adhesive Anchoring System with stainless steel threaded rod materials has also been found to be in compliance with the High-Velocity Hurricane Zone provisions of the *Florida Building Code—Building* and the *Florida Building Code—Residential* when the following condition is met:

The design wind loads for use of the anchors in a High-Velocity Hurricane Zone are based on Section 1620 of the *Florida Building Code—Building*.

Use of the the Red Head C6+ Adhesive Anchoring System with carbon steel threaded rod materials and reinforcing bars for compliance with the High-velocity Hurricane Zone provisions of the *Florida Building Code—Building* and the *Florida Building Code—Residential* has not been evaluated and is outside the scope of this supplemental report.

For products falling under Florida Rule 9N-3, verification that the report holder's quality-assurance program is audited by a quality-assurance entity approved by the Florida Building Commission for the type of inspections being conducted is the responsibility of an approved validation entity (or the code official, when the report holder does not possess an approval by the Commission).

This supplement expires concurrently with the evaluation report, reissued September 2021.